

# TOTO®

Head Office  
Firmensitz  
Siège social  
Sede centrale

TOTO Europe GmbH  
Zollhof 2, 40221 Düsseldorf Germany  
Tel: +49 (0)700 8686 0700

- You are advised to record the following information to allow quick service.
- Halten Sie bitte folgende Informationen fest, damit ein schneller Kundenservice möglich ist.
- Nous vous conseillons de noter les informations suivantes afin de faciliter l'entretien.
- Si prega di registrare i seguenti dati per accelerare gli interventi di assistenza.

Date of purchase : Kaufdatum: Date d'achat : Data di acquisto:	Name of shop : Name der Verkaufsstelle: Nom du magasin : Nome del negoziante:
Date : year month day Datum: Jahr Monat Tag Date : jour mois année Data: anno mese giorno	Tel / Tél:

©TOTO Ltd. All rights reserved.  
©TOTO Ltd. Alle Rechte vorbehalten.  
©TOTO Ltd. Tous droits réservés.  
©TOTO Ltd. Tutti i diritti riservati.

2009. 2. 27  
H06313  
Printed in Japan.  
Gedruckt in Japan.  
Imprimé au Japon.  
Stampato in Giappone.

# TOTO®

## NEOREST SE, LE CW997DF, CW998DF

## NEOREST®

TOTO® NEOREST SE, LE CW997DF, CW998DF



<b>Cautions and warnings</b> . . . . .	<b>GB_2</b>	<b>Introduction</b>
<b>Precautions for use</b> . . . . .	<b>GB_7</b>	
<b>Efficient use</b> . . . . .	<b>GB_8</b>	
<b>Overview of features</b> . . . . .	<b>GB_9</b>	
<b>Names of parts</b> . . . . .	<b>GB_10</b>	
<b>Before use</b> . . . . .	<b>GB_14</b>	

<b>Standard use of the NEOREST</b> . . . . .	<b>GB_18</b>	<b>Operation</b>
<b>Convenient functions</b> . . . . .	<b>GB_20</b>	
• Adjusting the temperature . . . . .	<b>GB_20</b>	
• Using the deodorizer . . . . .	<b>GB_22</b>	
• Opening/closing the seat and lid . . . . .	<b>GB_24</b>	
• Flushing the toilet . . . . .	<b>GB_25</b>	
<b>Energy Saver functions</b> . . . . .	<b>GB_27</b>	
• Using the Energy Saver timer . . . . .	<b>GB_28</b>	
• Using the Smart Energy Saver . . . . .	<b>GB_30</b>	

<b>Cleaning the NEOREST</b> . . . . .	<b>GB_32</b>	<b>Cleaning</b>
• Daily cleaning . . . . .	<b>GB_33</b>	
• Thorough cleaning . . . . .	<b>GB_34</b>	
• Cleaning the main unit and seat . . . . .	<b>GB_34</b>	
• Periodic cleaning . . . . .	<b>GB_36</b>	
• Cleaning the mains plug . . . . .	<b>GB_36</b>	
• Cleaning the deodorizer filter . . . . .	<b>GB_36</b>	
• Cleaning the wand . . . . .	<b>GB_37</b>	
• Cleaning the drain valve with built-in water filter . . . . .	<b>GB_38</b>	

<b>Changing settings</b> . . . . .	<b>GB_39</b>	<b>Settings</b>
• Remote control sound . . . . .	<b>GB_39</b>	
• Setting whether or not the remote control makes sound . . . . .	<b>GB_39</b>	
• Automatic opening and closing . . . . .	<b>GB_39</b>	
• Setting whether or not automatically open and close the lid . . . . .	<b>GB_39</b>	
• Changing the amount of time before the seat and lid closes . . . . .	<b>GB_40</b>	
• Opening the lid/opening the seat and lid automatically . . . . .	<b>GB_40</b>	
• Standard Deodorizer . . . . .	<b>GB_41</b>	
• Setting automatic operation of the standard deodorizer . . . . .	<b>GB_41</b>	
• Setting automatic use of the Power Deodorizer . . . . .	<b>GB_41</b>	
• Automatic Power Deodorizer . . . . .	<b>GB_41</b>	
• Setting automatic use of the Power Deodorizer . . . . .	<b>GB_41</b>	
• Automatic flushing . . . . .	<b>GB_42</b>	
• Setting automatic flushing . . . . .	<b>GB_42</b>	
• Setting the delay until the automatic flushing starts . . . . .	<b>GB_42</b>	
• Water pressure and washing position . . . . .	<b>GB_43</b>	
• Making the unit remember the last water pressure and washing position settings . . . . .	<b>GB_43</b>	

<b>Responding to power cuts and water outages</b> . . . . .	<b>GB_44</b>	<b>Troubleshooting</b>
<b>Preventing damage from freezing and measures for long-term disuse</b> . . . . .	<b>GB_45</b>	
<b>Troubleshooting</b> . . . . .	<b>GB_49</b>	
<b>Specifications</b> . . . . .	<b>GB_60</b>	

<b>Warranty</b> . . . . .	<b>GB_61</b>
---------------------------	--------------

<b>Important User Guidance Information</b> . . . . .	<b>GB_62</b>
--	--------------

- Thank you very much for purchasing this NEOREST. Please read this manual carefully and use the NEOREST correctly. Keep this instruction manual for future reference.
- "NEOREST" is a registered trademark of TOTO.



# Cautions and warnings

## Always observe these warnings.





Please read these cautions and warnings carefully and use the equipment correctly.

Follow all safety precautions and warnings.

- The meanings of these indications are as follows.



 <b>WARNING</b>	When this appears next to a topic, this indicates that misoperation could result in death or serious injury.
 <b>CAUTION</b>	When this appears next to a topic, this indicates that misoperation may result in injury or physical damage.

- The following symbols are used to classify and explain instructions that must be followed.

Symbol example	Meaning of symbol
	The  symbol indicates something that is prohibited.
	The  symbol indicates something that must be done.

- This equipment is Class 1, so it is necessary to attach it to an earthed connection.
- Install this equipment close to a mains socket.
- This equipment is not to be used by any person who has reduced physical, sensory or mental abilities (including children), nor is it to be used by any person who lacks sufficient experience or knowledge. However, such persons may use the equipment when a person who takes responsibility for their safety provides supervision and direction. Children must be supervised to make certain that they do not play with the equipment.
- Use the new hose set included with this equipment. Do not reuse an old hose set.

## WARNING

 Do not wet	<p><b>Do not wet the main unit or mains plug with water or cleaning fluid.</b></p> <ul style="list-style-type: none"> <li>Doing so could cause fire or electric shock.</li> <li>If the toilet breaks, injury or flooding of the room containing the unit could result.</li> </ul>
 Required	<p><b>Since this is electronic equipment, do not locate it in a place where it might be splashed or otherwise become wet. Likewise, do not locate it in a humid place where water could drip onto the surface of the NEOREST. When using it in a bathroom, install a ventilation fan or ventilation opening, so that the bathroom has sufficient airflow.</b></p> <p><b>Install the NEOREST at least 0.6 m away from any bathtub.</b></p> <ul style="list-style-type: none"> <li>Failure to observe this caution may result in fire or electrical shock.</li> </ul> <p><b>Prepare the socket for the electrical wiring as follows.</b></p> <ul style="list-style-type: none"> <li>Failure to observe this caution may result in fire or electrical shock.             <ol style="list-style-type: none"> <li>Provide electric current to the socket (device) using a differential residual electric current device (DDR) with a released current that does not exceed 30 mA.</li> <li>Locate the socket (device) and its wiring plug at least 0.6 m from the outside edge of a shower chamber or bathtub.</li> </ol> </li> <li><b>* Confirm that the wiring for items a and b above has been completed. If the wiring has not been completed, request completion from the business that installed the unit.</b></li> </ul>

## WARNING

**Confirm that the earth wire has been installed properly.**

- If the earth wire is not installed, electric shocks could occur if there is a malfunction or a short circuit.

Note:

Use copper wire with a diameter of 1.6 mm or more and with an earth resistance of 100  $\Omega$  or less.

- \* If the earth wire has not been installed, request installation from the business that installed the unit.

**Always insert the electrical cord completely into the socket (220-240 V AC, 50 Hz).**

- Failure to observe this caution may result in fire or electrical shock.

\* Follow the installation requirements for the country in which the NEOREST is being installed.

**Always connect the NEOREST to the cold water supply.**

- Failure to do so could cause burns or malfunction of the equipment.

Ventilation fan or ventilation opening

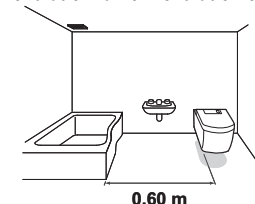

0.60 m



Required

**Be careful to prevent low-temperature burns.**

- When seated on the NEOREST for a long time, set the seat temperature to "off".
- Before the following types of people use the heated seat or warm air dryer, someone else should set the seat temperature to "off" and the dryer temperature to "low".

- Children, elderly and other people who cannot adjust the temperature suitably themselves.
- Sick or physically disabled people and others who might not be able to move freely.
- People who have taken medication that causes drowsiness (sleep aids, cold medicine, etc.), people who have drunk much alcohol, extremely fatigued people and others who might fall asleep unintentionally.

**Remove dust that has adhered to the mains plug blades or other parts regularly and insert it in the socket completely.**

- Dust could cause fire or electrical shock. Remove the plug and wipe it with a dry cloth.

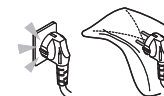

**When removing the mains plug, always hold and pull the plug itself.**

- If you pull on the cord, the plug and cord could be damaged, and fire or electrical shock could result.

**To Reduce the danger of burns, death from electric shock, fire or other human injury:**

- Close supervision is necessary when this product is used by or near children or invalids.
- Use this product only for its intended use as described in this manual. Do not use accessories not recommended by the manufacturer.
- Keep the cord away from heated surfaces.
- Connect this product to a properly earthed socket only. See the Earthing Instructions.
- The tank should only be filled with water.



Do not disassemble

**Never disassemble, repair or modify the device.**

- This could cause fire or electric shock.









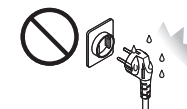

Do not touch with wet hands

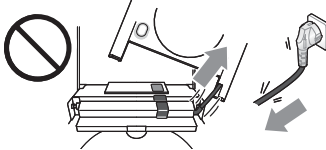
**Do not remove the mains plug with wet hands.**

- This could cause electric shock.

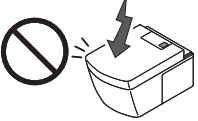
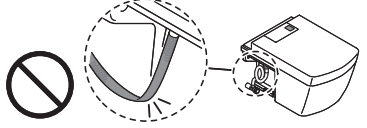

 <b>WARNING</b>	
 Prohibited	<p><b>Do not continue to use the NEOREST that is broken or malfunctioning.</b></p> <ul style="list-style-type: none"> <li>In the following situations, disconnect the mains plug and close the water shut-off valve to stop the water supply.</li> </ul> <div style="background-color: #cccccc; padding: 5px;"> <p><b>Possible malfunctions</b></p> <ul style="list-style-type: none"> <li>Water is leaking from plumbing or the main unit.</li> <li>The NEOREST has a crack or a break.</li> <li>There is a strange sound or smell.</li> <li>Smoke is coming from the NEOREST.</li> <li>The NEOREST is unusually hot.</li> <li>The toilet is blocked.</li> </ul> </div> <ul style="list-style-type: none"> <li>Continued use of a malfunctioning or broken unit could cause fire, electric shock, or flooding of the room containing the unit.</li> </ul>
	<p><b>Do not do anything that could damage the power cord or seat cord.</b></p> <div style="background-color: #cccccc; padding: 5px;"> <p><b>Do not pull, twist, excessively bend, intentionally damage, alter or heat the cords. Do not put heavy items on them.</b></p> </div> <ul style="list-style-type: none"> <li>Continued use of a unit with a damaged cord could cause fire, electric shock, or a short circuit.</li> </ul> 
	<p><b>Do not use a loose mains socket.</b></p> <ul style="list-style-type: none"> <li>This could cause fire or electric shock.</li> </ul>
	<p><b>Do not use this product with any power supply other than specified (220-240 V AC, 50 Hz).</b></p> <ul style="list-style-type: none"> <li>Failure to observe this caution may result in fire or electrical shock.</li> </ul>
	<p><b>Do not use sockets or wiring equipment exceeding the rated values.</b></p> <ul style="list-style-type: none"> <li>Use of multi-prong mains adapters and other actions that exceed the rated values could cause fire from excess heat.</li> </ul>
	<p><b>Use only tap water or potable well water (groundwater).</b></p> <ul style="list-style-type: none"> <li>Use of other water could cause skin inflammation or other problems.</li> </ul>
	<p><b>To Reduce the danger of burns, death from electric shock, fire or other human injury:</b></p> <ul style="list-style-type: none"> <li>Never operate this product if it has a damaged cord or plug, if it is not working properly, if it has been dropped or damaged, or if it has been dropped in water. Return the product to TOTO Europe GmbH for examination and repair.</li> <li>Never block the air openings of the product or place it on a soft surface, such as a bed or a couch, where the air openings could be blocked. Keep the air openings free of lint, hair or a similar material.</li> <li>Never use it while sleepy or drowsy.</li> <li>Never drop or insert anything into any opening or hose.</li> <li>Do not use outdoors or operate where aerosol (spray) products are being used or where oxygen is being administered.</li> </ul>
<div style="display: flex; align-items: center;">  <p><b>Always disconnect the mains plug from the socket when cleaning.</b></p> <ul style="list-style-type: none"> <li>Failure to do so could cause electric shock.</li> </ul> <p>* Use of the "WAND CLEANING button" is an exception to this rule.</p>  </div>	

 <b>CAUTION</b>	
 Flammable	<p><b>Do not bring lit cigarettes or other burning materials near the NEOREST.</b></p> <ul style="list-style-type: none"> <li>Doing so could cause fire.</li> </ul>
 Prohibited	<p><b>Do not put a finger or object in the warm air blower.</b></p> <div style="background-color: #cccccc; padding: 5px;"> <p><b>Do not place objects on the warm air blower or cover it with clothing.</b></p> </div> <ul style="list-style-type: none"> <li>Doing so could cause burns, electric shock or burnout.</li> </ul> 
	<p><b>Do not subject the main unit to strong force or a sudden shock. Do not climb on the seat, the toilet lid or any other part of the main unit. Do not put heavy objects on it.</b></p> <ul style="list-style-type: none"> <li>Injury could result if it breaks or the main unit becomes dislodged and falls.</li> <li>If the toilet breaks, flooding of the room containing the unit could result.</li> </ul> 
	<p><b>When cleaning plastic parts, including the seat and lid, use diluted (pH-neutral) kitchen cleaning detergent. Do not use the following:</b></p> <p>Toilet cleaner, household cleaner, benzene, paint thinner, cleanser powders, nylon scrubbing pads, etc.</p> <ul style="list-style-type: none"> <li>These could damage the plastic or cause cracks, which could lead to injury.</li> <li>These could damage the water supply hose, resulting in water leaks.</li> </ul>
	<p><b>Do not detach the drain valve with built-in water filter while the water shut-off valve is still open.</b></p> <ul style="list-style-type: none"> <li>Doing so will cause water to spill.</li> </ul> <p style="text-align: right;">▶ See "Cleaning the drain valve with built-in water filter" on page 38.</p>
	<p><b>Do not flush anything in the toilet other than toilet paper or excrement.</b></p> <ul style="list-style-type: none"> <li>Doing so could block the toilet, causing wastewater to overflow and flood the room.</li> </ul>
	<p><b>Do not bend or crush the water supply hose.</b></p> <ul style="list-style-type: none"> <li>This could cause a water leak.</li> </ul> 
<p><b>To reduce the danger of death from electric shock:</b></p> <ul style="list-style-type: none"> <li>Do not use while bathing.</li> <li>Do not place or store the product where it could fall or be pulled into a tub or sink.</li> <li>Do not put in or drop into water or other liquid.</li> <li>Do not try to recover it if it has fallen into water. Unplug it immediately.</li> </ul>	
<p><b>Do not run hot water through the bowl.</b></p> <ul style="list-style-type: none"> <li>Using hot water might break the bowl and cause injury.</li> </ul>	
<p><b>If a crack occurs in a ceramic part or the ceramic breaks, never touch damaged parts.</b></p> <ul style="list-style-type: none"> <li>Damaged parts could cause injury. Replace them as soon as possible.</li> </ul>	

# Precautions for use

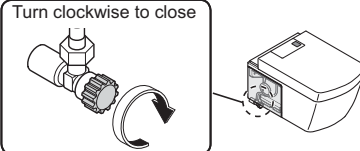
<b>⚠ CAUTION</b>	
<b>!</b> Required	<p><b>If the NEOREST will not be used for a long time, close the water shut-off valve, drain the water and disconnect the mains plug.</b></p> <ul style="list-style-type: none"> <li>For safety, disconnect the mains plug. ▶ See "Draining the water" on page 47.</li> <li>Run water through the NEOREST before using it again because water left in the unit may have spoiled and could cause skin inflammation or other problems. ▶ See "Restoring the water supply after draining the NEOREST" on page 48.</li> </ul>
	<p><b>If a water leak occurs, close the water shut-off valve and stop the water supply.</b></p> <div style="display: flex; align-items: center;"> <div style="border: 1px solid black; padding: 5px; margin-right: 10px;">Turn clockwise to close</div>  </div>
	<p><b>Thoroughly tighten the drain valve with built-in water filter.</b></p> <ul style="list-style-type: none"> <li>Failure to do so could cause a water leak.</li> </ul>
	<p><b>Prevent damage from freezing.</b></p> <ul style="list-style-type: none"> <li>Freezing could cause damage to the water supply plumbing and the inside of the NEOREST and result in a leak.</li> <li>Use a heater or otherwise keep the toilet warm. ▶ See "Preparation for freezing conditions" on page 45.</li> </ul>
	<p><b>If the toilet becomes blocked, disconnect the mains plug, and remove the blockage with a plunger (rubber cup) that can be purchased in a store.</b></p> <ul style="list-style-type: none"> <li>If you do not disconnect the mains plug, automatic washing will function, which could cause wastewater to overflow and flood the room.</li> </ul>

## Earthing Instructions

This product must be earthed. If an electrical short circuit occurs, earthing reduces the risk of electric shock by providing an escape wire for the electrical current. This product is equipped with a cord that has an earth wire and an earthing plug. The plug must be plugged into a socket that is properly installed and earthed.

### Improper use of the earthing plug can result in the risk of an electric shock.

If the cord or plug requires repair or replacement, do not connect the earthing wire to either of the flat blade terminals. The earth wire has insulation that is green on the outside and might or might not have yellow stripes. Check with a qualified electrician or serviceman if you do not completely understand the earth wire instructions or have a doubt about whether the product is properly earthed.

This product is equipped at the factory with a specific electrical cord and plug that allow connection to a suitable electrical circuit. Confirm that the product is connected to a socket with the same configuration as the plug. Do not use an adapter with this product. Do not modify the included plug. If the plug and socket are not compatible, have a suitable socket installed by a qualified electrician. If the product must be reconnected for use with a different type of electrical circuit, qualified service personnel must conduct the reconnection.

If it is necessary to use an extension cord, use only a three-wire extension cord that has a three-blade earthing plug and a three-slot socket that accepts the plug on the product cord. Replace or repair a damaged cord.

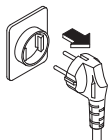

Save these instructions.

## Please follow these instructions regarding the NEOREST.

**Do not wipe the main unit, seat or toilet lid with dry cloth, toilet paper or similar materials.**

▶ "Cleaning the NEOREST" on page 33.

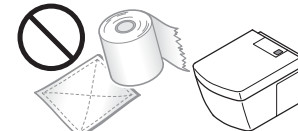

**Do not lean against the toilet lid.**

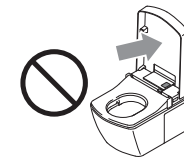

**Avoid urinating on the main unit and wand.**

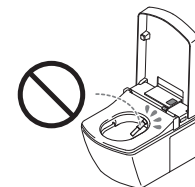

**Disconnect the mains plug during thunderstorms.**

• The mains plug is behind the right cover panel. Removing the cover panel ▶ See page 16.

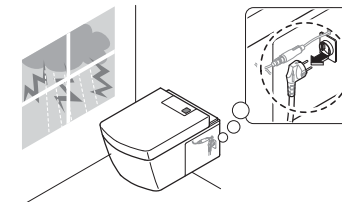

**Do not cover the seat sensor, the body detection sensors or the remote control signal transmitter and receiver.**

• This could cause the NEOREST not to function properly.



**Use radios and similar devices away from the NEOREST.**

• The NEOREST could cause interference to the radio signal.

**Do not expose to direct sunlight.**

• This could cause the colour to change and variation of the temperature of the heated seat, as well as remote control failure and other malfunction of the NEOREST due to temperature changes.

**After using an infant support seat on top of the NEOREST seat, remove it.**

• Some functions might not be useable when such a seat is on the NEOREST.

### Is there any way to eliminate unpleasant "splashes" when using the toilet?

Tip ➡ 1

Splashes that occur when using the toilet, as well as urine splashes that occur when males urinate while standing, are caused by the water that is kept in the toilet. Depending on the shape and amount of excrement, the angle and force of urine and other factors, water sometimes splashes. This water, however, is necessary to create a barrier that blocks odours from sewage, so it cannot be eliminated. Placing a layer of toilet paper on top of the water before use is one way to slightly reduce splashing. Moreover, urinating into the centre of the water can slightly reduce urine splashing.

## Efficient use

Skilfully save energy and water to protect the global environment.

### Timer-based Energy Saver

#### Timer-based Energy Saver

► See page 27.

Once this is set, the seat heater will turn off at the same time every day to save energy. The duration of the Energy Saver can be set to 3, 6 or 9 hours.

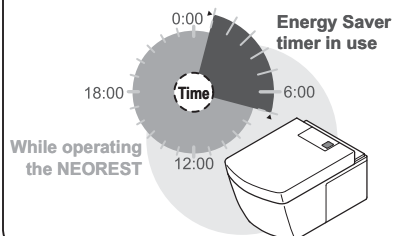

#### Smart Energy Saver

► See page 27.

This function conserves energy by remembering time periods when the toilet is not used much and automatically lowering the seat temperature.

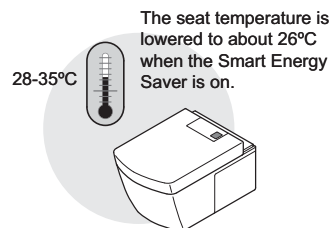

The Energy Saver Timer and the Smart Energy Saver can both be used at the same time.

### Set the temperature lower

To conserve energy set the temperature just high enough so that the seat does not feel cold.

► See page 20.

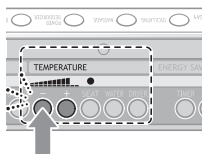

### Close the toilet lid

By closing the toilet lid, less warmth escapes from the seat surface, conserving energy.

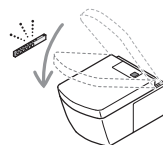

### Set the Operation on/off button to "off" when the NEOREST will not be used for a long time

When going out, for example, set  to "off" to conserve energy.

► See page 17.

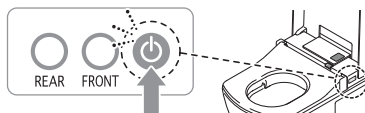

## Overview of features

The product name and number are printed on the underside of the lid.

Washing functions		Page
Rear wash	Wash the rear.	18
Soft wash	Washes the rear with a gentle water flow.	18
Front wash	Use as a bidet for women.	18
Washing position adjustment	Adjust the wand position forward and backward.	18
Water pressure adjustment	Adjust the water pressure.	18
Oscillating wash	Moves the wand forward and backward for thorough cleaning over a wide area.	18
Massage wash	Washes with water pressure that varies in strength.	18

Amenities		Page
Heated seat	Warms the toilet seat.	-
Warm air dryer	Dries wet areas.	18
Temperature adjustment	Adjusts the temperatures of the warm water, the seat and drying.	20
Deodorizer	Eliminates odours inside the toilet.	22
Power Deodorizer	Eliminates odours inside the toilet with even greater suction power.	23
Automatic Power Deodorizer	Automatically operates the Power Deodorizer when a person leaves the seat.	22
Remote control	Control the NEOREST from a comfortable position.	13
Seat sensor	Makes various functions operate when a person sits on the seat.	19
Remote control seat and lid opening/closing	The seat and lid can be opened and closed using the remote control.	24
Automatic opening and closing	When a person is detected the lid opens and closes automatically.	24
Remote control toilet flushing	The toilet can be flushed using the remote control.	25
Automatic flushing	The toilet flushes automatically when a person leaves the toilet.	26

Energy Saver functions		Page
Timer-based Energy Saver	Once this is set, the seat heater will turn off at the same time every day to save energy. (The duration of Energy Saver can be set to 3, 6 or 9 hours.)	27, 28, 29
Smart Energy Saver	This function conserves energy by remembering time periods when the toilet is not used much and automatically lowering the seat temperature.	27, 30
Operation on/off button	By turning this button "off", the operation of the heated seat and other functions can be stopped for thorough energy conservation.	17

Cleaning features		Page
Seat attachment and removal	The seat can be removed easily. This also helps make cleaning easy.	34, 35
Self-cleaning	The wand tip is automatically cleaned thoroughly before and after washing.	-
Clean coat wand	The wand itself has a coating that makes it difficult for grime to stick to it.	-
WAND CLEANING button	The wand can be extended without emitting water for easy cleaning.	37
Toilet that is easy to keep clean	CeFiONtect technology keeps grime from sticking to the toilet and makes it easy to remove.	-
Dirty water barrier gasket	Keeps the space between the main unit and toilet clean.	10
No underside edge	We eliminated the underside edge of the toilet overhang.	-
Full covered lid	The surface can be cleaned with one quick wipe.	-



# Names of parts

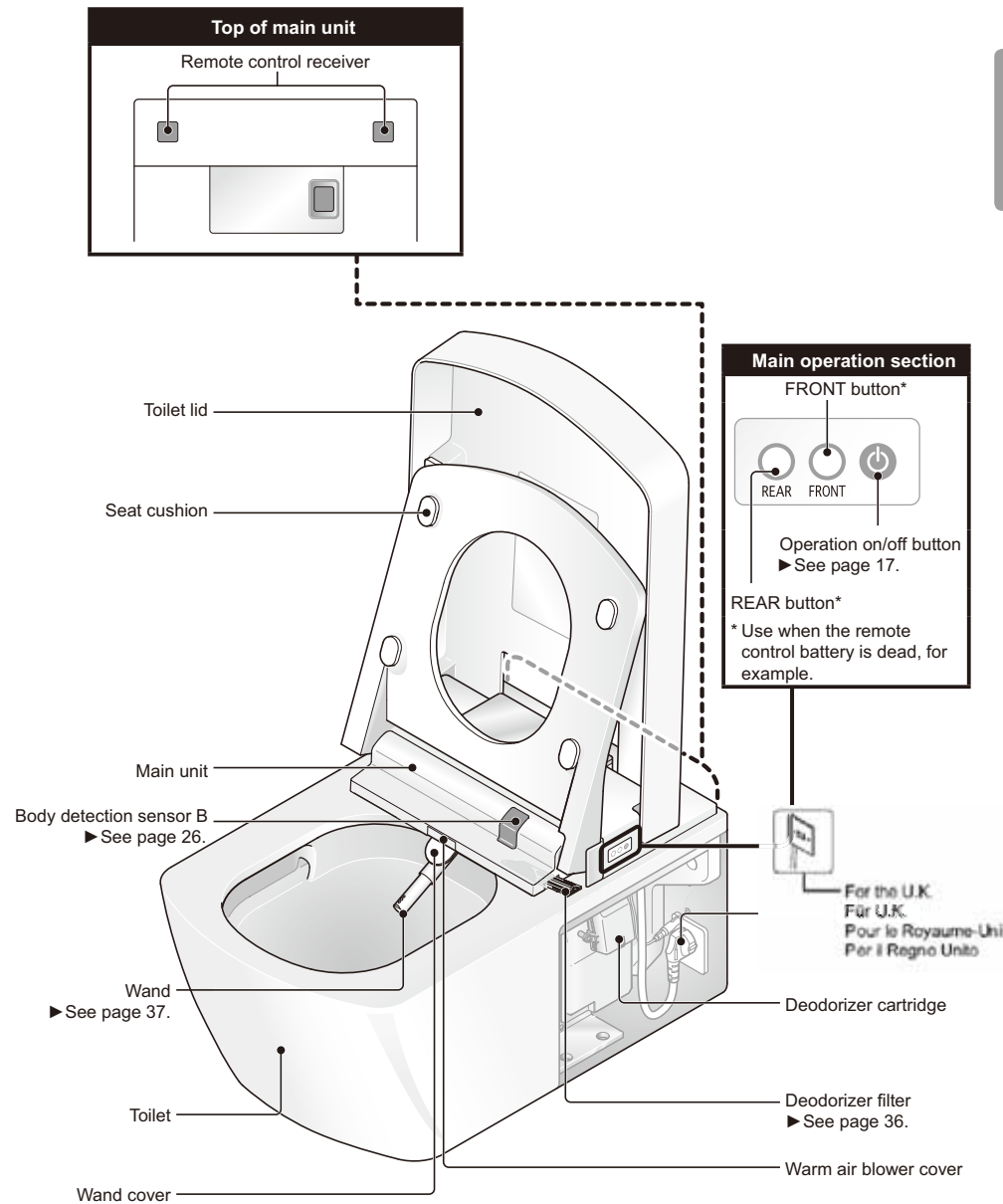
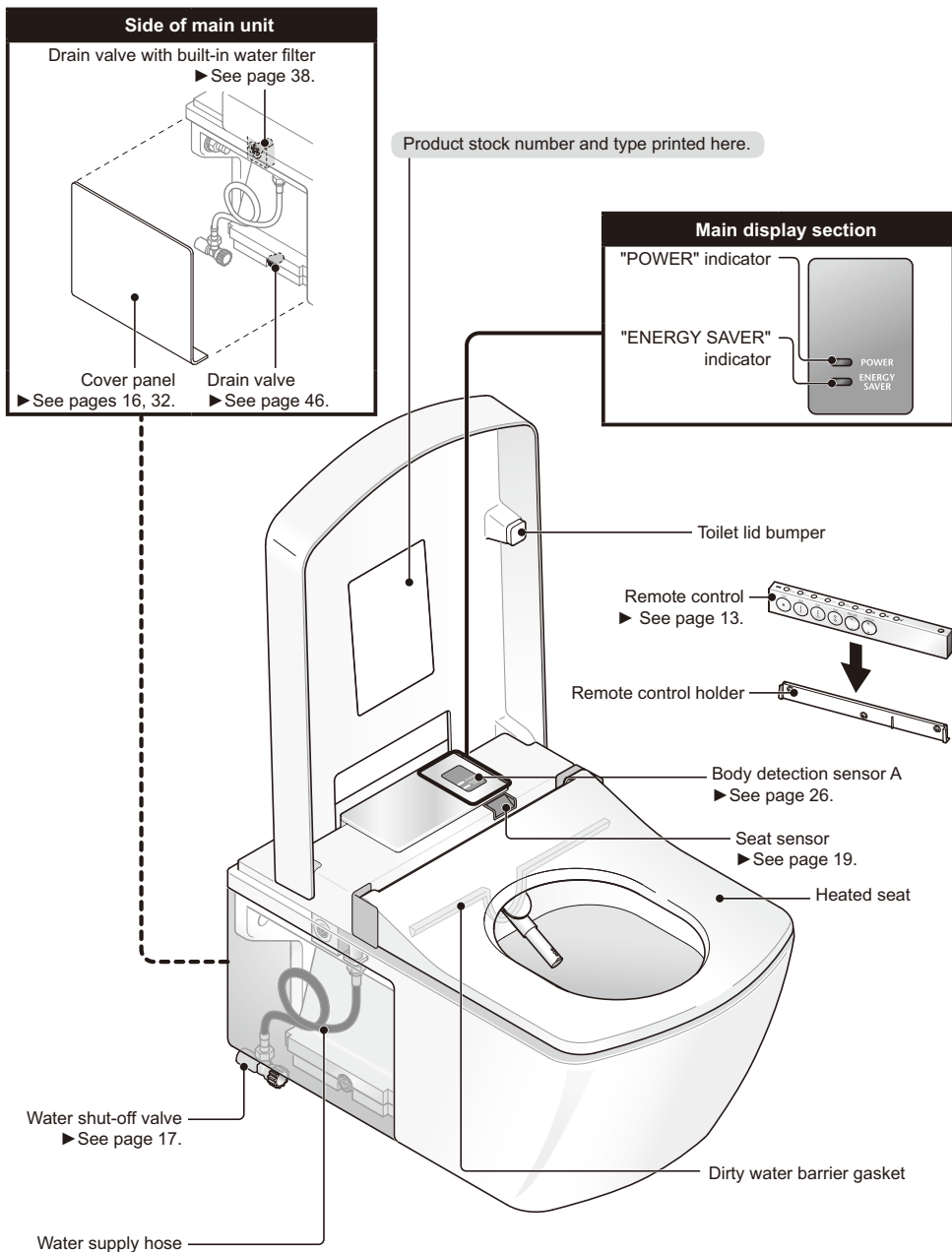

(NEOREST SE illustration)

The shapes of the lid and the display section are different on the NEOREST LE.

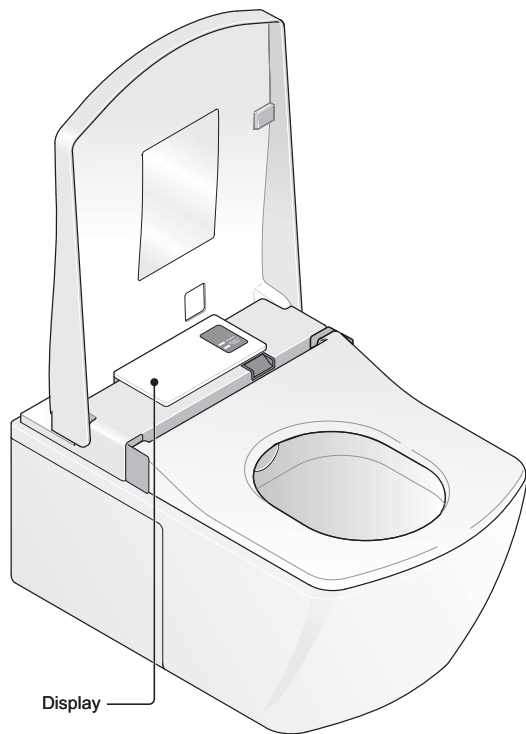

Display

(When the lid is open)

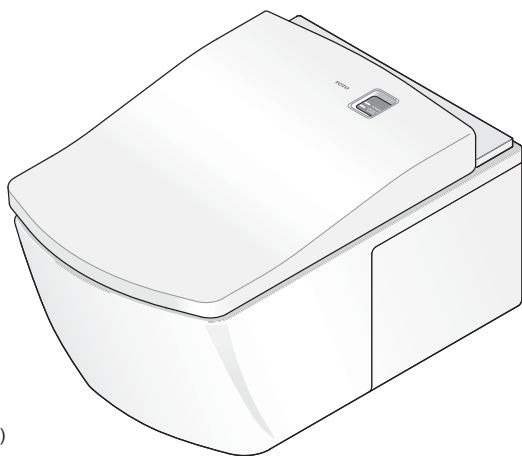

(When the lid is closed)

• NEOREST SE illustrations are used in the explanations in this manual.

## Remote control

### Front

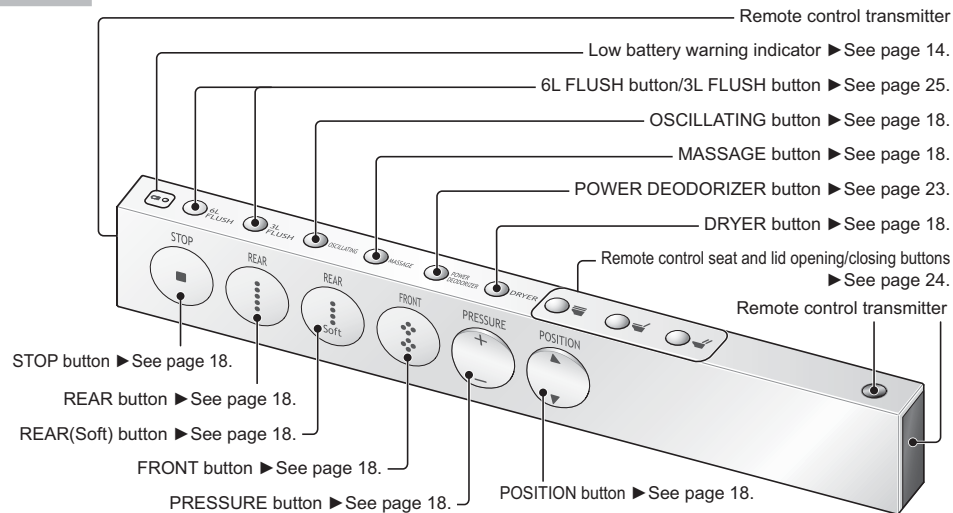

### Back

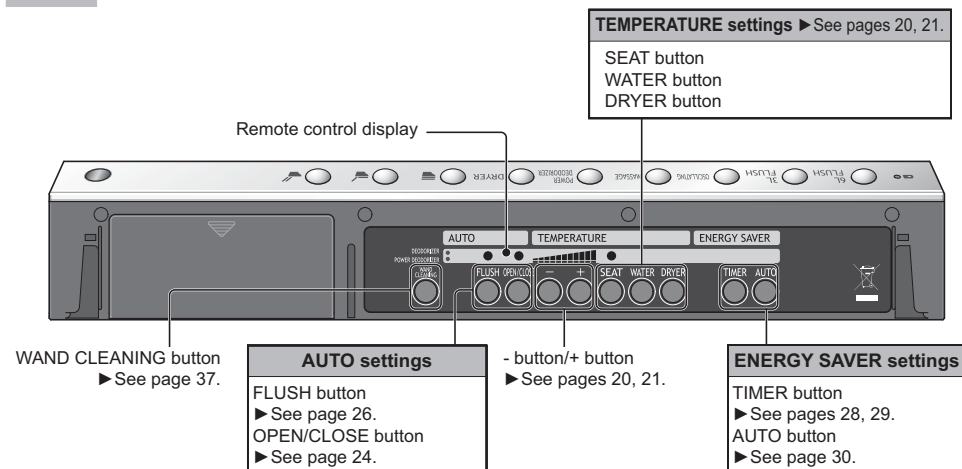

• The low battery warning indicator blinks when the batteries are running out of power. Change the batteries as soon as possible. ▶ See page 14.

### About the electronic sounds

- When a remote control button is pressed and the main unit receives a signal, the unit produces an electronic sound. This unit uses three types of electronic sounds.
  - Short beep** ..... Sounds when a remote control button is pressed and the main unit receives a signal.
  - Long beep** ..... Sounds when the "STOP" button is pressed, when any function (timer-based Energy Saver, oscillating wash, etc.) is turned off.
  - Double beep** ..... Sounds when the Water or Seat Temperature are set to their "high" settings.



# Before use

## Put batteries in the remote control

### 1 Remove the remote control from the remote control holder.

- Grasp the sides of the remote control with both hands and lift straight up.

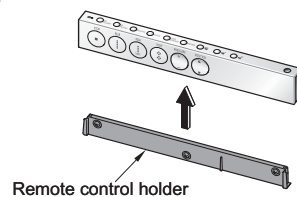

### 2 Open the battery cover on the back of the remote control and properly insert two AA batteries.

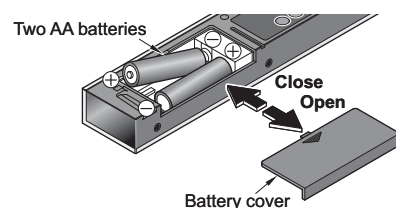

### 3 Close the battery cover.

◆ Check here

#### Remote control display

When the batteries are inserted properly, the display section on the back of the remote control will appear as in this illustration after all indicators have lit.

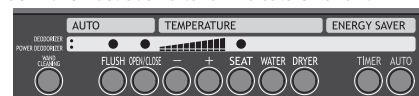

### 4 Reattach the remote control to the remote control holder.

#### About the batteries

Please use alkaline batteries.

Observe the following precautions to keep batteries from splitting or leaking.

- When replacing them, use two new batteries of the same brand.
- Remove the batteries when not using the remote control for a long time.
- Do not use rechargeable batteries.

**When to change the batteries**

The low battery warning indicator on the remote control blinks when the batteries are running out of power. Put in new batteries as soon as possible.

Depending on the size of the room, the materials and forms of walls, floors and other elements, transmission might stop working even before the low battery warning indicator starts blinking. Insert new batteries if this occurs.

## When fixing the remote control to prevent theft

- Loosen the locking attachment screws, and detach the remote control. Tighten the screws thoroughly when replacing them to fix the attachments in place.
- Use a Phillips head screwdriver with a fine head (No.1 bit size or precision screwdriver).
- When replacing the screws, after they are tight do not try to tighten them more. Doing so could damage the remote control holder or other parts.

### 1 Loosen the locking attachments (one left, one right) using a Phillips head screwdriver.

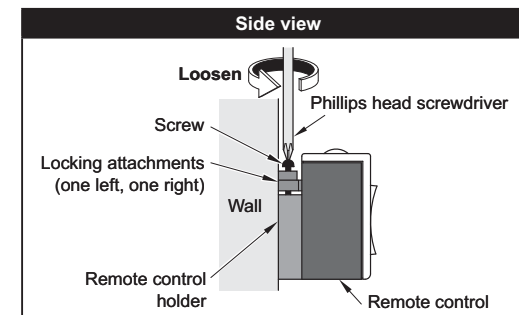
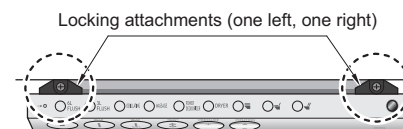

### 2 Remove the remote control from the remote control holder.

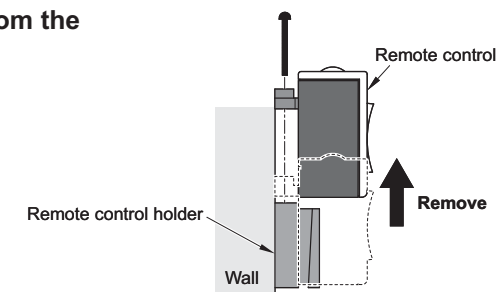

## Turning on the power and preparing the unit

The mains plug is behind the right cover panel.

Follow the same procedures for both right and left cover panels when attaching and removing them.  
Be careful! Dropping could cause damage!

### 1 Remove the cover panel.

- Use a flat-blade screwdriver to loosen the screws on the bottom of the cover panel (right), pull it out by the bottom slightly, and then pull the cover down and out.

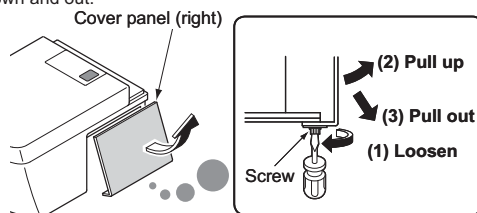

### 2 Insert the mains plug in the socket.

- The "POWER" indicator lights automatically.
- The toilet flushing starts automatically.

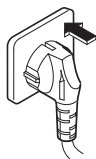

### 3 Reattach the cover panel.

- Align the cover panel (right) with the panel attachment guideline and fix it by tightening the bottom screws with a flat-blade screwdriver.

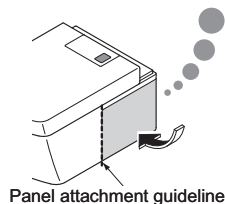
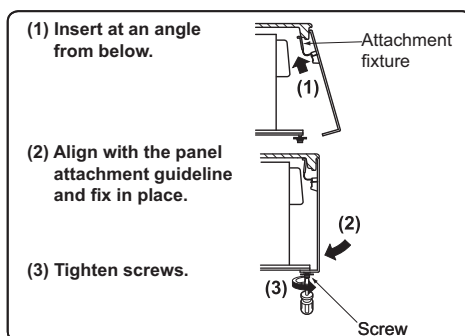

## Opening the water shut-off valve

- Turn the water shut-off valve in the direction of the arrow to open it completely.

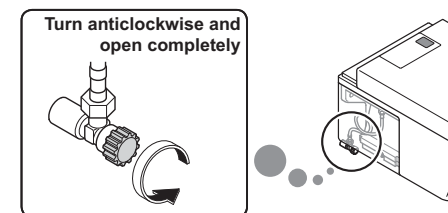

## Checking the main display section

Is the main display section "POWER" indicator lit?

\* If the "POWER" indicator is not lit, none of the functions can be used.  
(Excluding when Energy Saver is in use. ▶ See page 27.)

Press  in the main operation section. (The "POWER" indicator lights.)

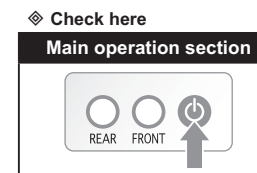
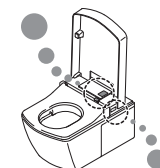
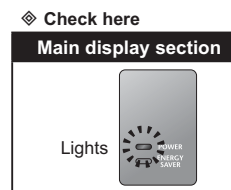

### Turning off the power

Press  to turn off the power.

- The "POWER" indicator goes off.

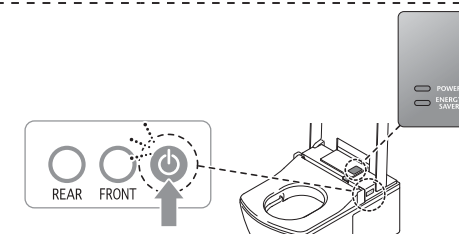

# Standard use of the NEOREST

## 1 Approach the toilet.

The lid automatically opens.

Opening the seat and lid ▶ See page 24.

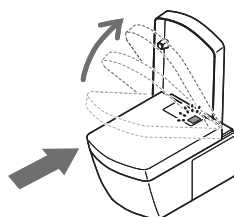

## 2 Sit on the seat.

The seat sensor detects the presence of a person and all the functions become operative.

- The deodorizer starts.  
Please test the Power Deodorizer.  
Using the Power Deodorizer ▶ See page 23.

## 3 Wash, dry and stop.

Perform operations with the remote control.

Tip 1

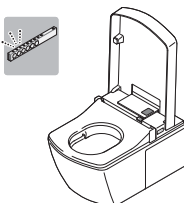

### STOP button

This button stops washing (rear and front) and drying.

### DRYER button

Warm air blown at wet areas dries them smoothly. Drying can be made even faster by lightly wiping away drops of water with toilet paper.

Special washing function 1  
▶ See below.

Special washing function 2  
▶ See below.

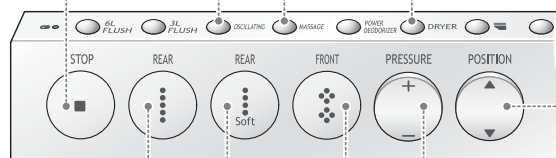

### REAR button

Use to wash the rear.

### REAR(Soft) button

Washes the rear with a gentle water flow.

### FRONT button

Use as a bidet.

### POSITION button

Use the button to adjust the washing position as you like (there are five positions). Press "▲" to move the position forward, and "▼" to move the position backward.

\* Every time you press the REAR, REAR(Soft) or FRONT button, the position is reset to the standard position (3rd step).  
To set a preferred washing position (See page 43)

### PRESSURE button

Use the button to adjust the water pressure as you like (there are five levels). Press "+" to increase the water pressure, and "-" to decrease the water pressure.

\* Every time you press the REAR, REAR(Soft) or FRONT button, the position is reset to the standard position (3rd step).  
To set the preferred water pressure (See page 43)

### Other convenient functions

#### Special washing function 1

##### Oscillating wash

This function moves the wand backward and forward to wash thoroughly over a larger area.

(1) Press the button to use.

(2) Press .  
This starts the oscillating wash.

(3) Press again.  
This stops the oscillating wash.

#### Special washing function 2

##### Massage wash

This function washes with varying water pressure.

(1) Press the button to use.

(2) Press .  
This starts the massage wash.

(3) Press again.  
This stops the massage wash.

## 4 Stand up from the seat.

- The Automatic Power Deodorizer starts. It stops after about two minutes.
- When you stand up from the seat, the wand extends partly and sprays water for about 30 seconds before returning to its inactive position.\*
- \* Water in the wand is emitted so that fresh water can be used every time.

The toilet flushing starts automatically after about 5 seconds.

Flushing ▶ See page 25.

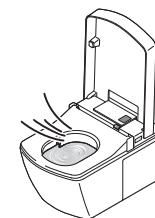

## 5 Move away from the toilet.

The lid closes automatically after about 90 seconds.

Closing the seat and lid ▶ See page 24.

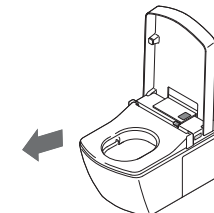

### Please be aware of these points

- Sometimes water comes out of the base of the wand during washing. This is a necessary function.  
\* When not washing, if water comes out continuously, this could be a malfunction.  
Close the water shut-off valve, and contact the installer or seller of this NEOREST.
- Water in the warm water tank expands and is sometimes emitted from the base of the wand.

### About the seat sensor

What is the seat sensor?

- The seat sensor detects when a person sits down.
- The seat sensor puts out Infrared rays, as shown in the illustration.
- The seat sensor might not work well in some conditions.

▶ See pages 49–59.

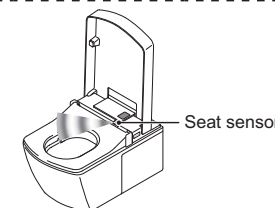

### Using the NEOREST if the remote control batteries are dead

- Press or in the main operation section to use the wash function.

(1) Confirm the POWER indicator in the main display section is on.

(2) Press or to select either rear or front washing.

(3) Press the same button again to stop washing.

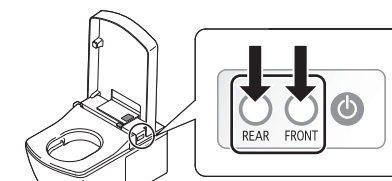

Tip 1

Please sit fully on the seat.

By doing so, the washing position will be more accurate and it is less likely that water will spray out from the NEOREST.

# Convenient functions

## Adjusting the temperature

You can use the remote control to adjust the warm water, seat and drying temperatures. Please set them to the temperatures you prefer.

### 1 Remove the remote control from the remote control holder.

If the remote control is fixed in place to prevent theft  
▶ See page 15.

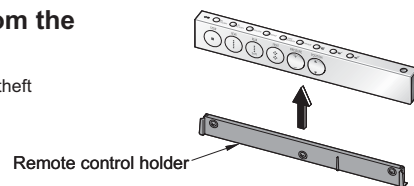

### 2 Adjust the temperature.

- Press **SEAT**, **WATER** or **DRYER** on the back of the remote control for the item that you want to adjust the temperature.

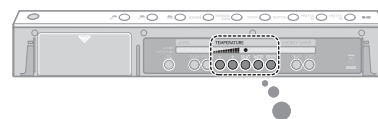

"●" lights up on the remote control display, and the currently set level can be checked.

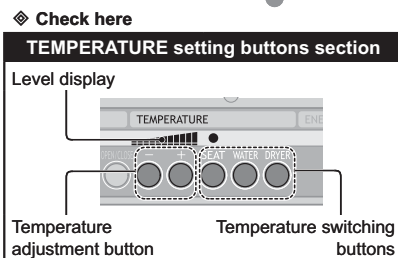

#### Temperature settings of the seat

- Press **SEAT**, and adjust the temperature with **+** and **-**.
- Press **+** until all the bars in the appropriate level display disappear to turn off the seat heater.
- The temperature can be set to one of five levels.

#### Back of the remote control

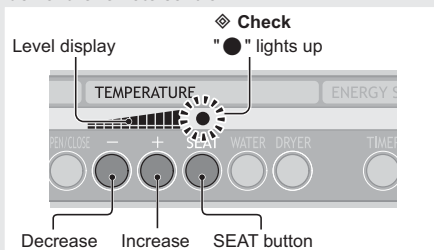

#### Setting the warm water temperature

- Press **WATER**, and adjust the temperature with **+** and **-**.
- Press **+** until all the bars in the appropriate level display disappear to turn off the seat heater.
- The temperature can be set to one of five levels.

#### Back of the remote control

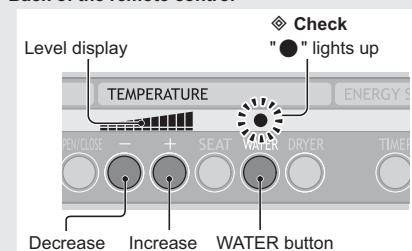

#### Setting the drying temperature

- Press **DRYER**, and adjust the temperature with **+** and **-**.
- The temperature can be set to one of five levels.
- There is no "off" setting.

#### Back of the remote control

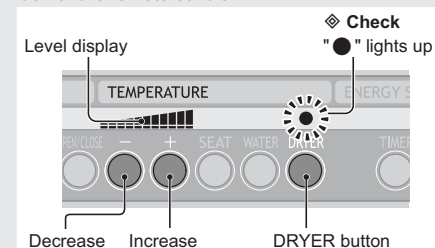

## Using the deodorizer

There are three deodorizer functions: [standard deodorizer], [Power Deodorizer] and [Automatic Power Deodorizer].

### Using the standard deodorizer and the Automatic Power Deodorizer

- The standard deodorizer works when someone sits on the seat.
- When someone gets up off the seat, the Automatic Power Deodorizer works, removing odour from inside the toilet.
- The standard deodorizer and the Automatic Power Deodorizer is set to "on" by default.

◆ Check here

#### Back of the remote control

Confirm that both the standard deodorizer and the Automatic Power Deodorizer are set to "on" on the display area at the back of the remote control.

◆ Check

When the standard deodorizer or Automatic Power Deodorizer is on, a "●" appears.

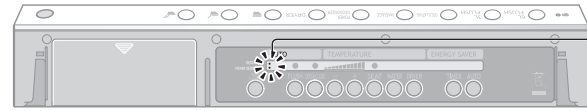

### 1 Sit on the seat.

The standard deodorizer starts.

### 2 Stand up from the seat.

The Automatic Power Deodorizer starts.  
It stops automatically after about 2 minutes.

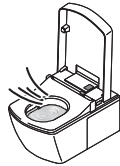

Turning off the standard deodorizer ► See page 41.

Turning off the Automatic Power Deodorizer ► See page 41.

## Using the Power Deodorizer

- Use this function when seated to increase the suction power and remove unwanted odours from the toilet.

Tip 1

### 1 Press on the remote control.

The Power Deodorizer starts.

◆ Check

#### Back of the remote control

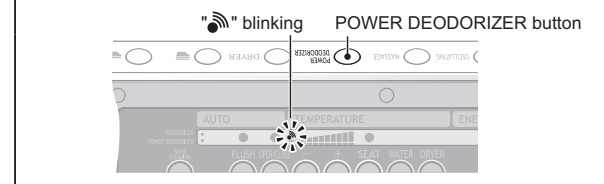

### 2 Press on the remote control again.

Standard deodorizer power resumes.

Tip 2

Tip 1

- The Power Deodorizer will not work if no one is sitting on the toilet. However, the Power Deodorizer button will function for about two minutes after a person gets up off the seat.

Tip 2

- If a person stands up without pressing the  button, it will stop automatically after about two minutes.

## Opening/closing the seat and lid

There are two ways to open and close the seat and lid: [Remote control opening and closing] and [Automatic opening and closing].

### Using the remote control to open and close the seat and lid

- The seat and lid can be opened and closed using the remote control buttons. (The remote control can also be used to open and close them even if automatic opening and closing are on.)

Tip 1

1 Press , , or on the remote control.

The seat and lid open or close.

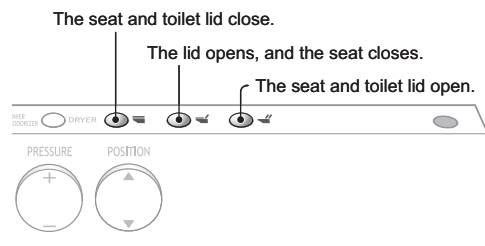

### Using automatic opening and closing

- When you approach the toilet, the lid opens automatically, and when you move away the toilet lid closes automatically.
- If you close the lid using the remote control or by hand, the lid will not open automatically for about 10 seconds. (This prevents the lid from reopening unnecessarily.)
- Automatic opening and closing are set to "on" when the unit is new.

◆ Check here

#### Back of the remote control

Check the display section on the back of the remote control to confirm that automatic opening and closing is on.

◆ Check

When automatic opening and closing is on, a "●" appears.

OPEN/CLOSE button

1 Approach the toilet.

The lid automatically opens.

- When a body detection sensor detects a person, the lid opens automatically.
- When urinating while standing, open the seat using the remote control. The seat can also be opened automatically. Opening and closing the seat and lid automatically ▶ See page 40.

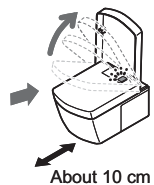

2 Move away from the toilet.  
After using the seat

- If no person is within about 30 cm of the toilet for about 90 seconds, the lid closes automatically.

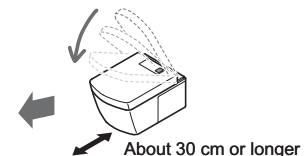

The lid automatically closes.

Turning off automatic opening and closing of the lid ▶ See page 39.

Changing the amount of time before the lid closes automatically ▶ See page 40.

After urinating while standing

- If no person is within about 30 cm of the toilet for about 90 seconds, the seat and lid close automatically.

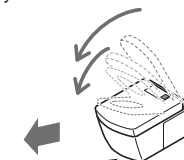

The seat and lid close automatically.

Opening and closing the seat and lid automatically ▶ See page 40.

## Flushing the toilet

There are two ways to flush after use: [flushing with the remote control] and [automatic flushing].

### Flushing with the remote control

- Use the remote control buttons for both light and heavy flushing. (You can use the remote control to flush even when automatic flushing is on.)

Tip 2

1 Press or .

The toilet flushing starts.

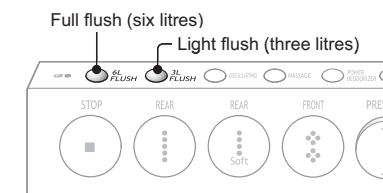

### Flushing when the remote control batteries are dead

- Press the flush panel button to flush the toilet.

(1) Press the flush panel button.

The toilet flushing starts.



Tip 1

- If there has been a power cut or the batteries are dead, open and close the seat and lid by hand.

Tip 2

- The 6L FLUSH/3L FLUSH button cannot be used repeatedly in rapid succession. Wait about 10 seconds after the water has stopped refilling the toilet.



## Using automatic flushing

- Automatic toilet flushing occurs when a person moves away from the toilet. (This prevents forgetting to flush.)
- Automatic flushing is on by default when the unit is new.

◆ Check here

### Back of the remote control

Check the display section on the back of the remote control to confirm that automatic flushing is on.

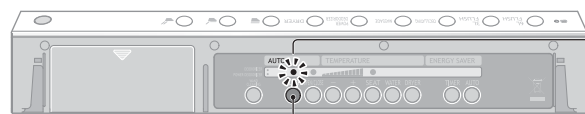

◆ Check  
When automatic flushing is on, a "●" appears.

FLUSH button

### After using the seat

- Automatic flushing does not start automatically unless sitting on the seat for more than 6 seconds.
- The toilet flushing starts automatically about 5 seconds after standing up from the seat.**

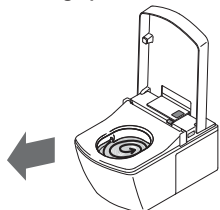

Tip 1

- The flushing volume changes automatically according to the amount of time seated on the seat.  
Between about 6 and 30 seconds ... light flush  
About 30 seconds or more ..... full flush
- \* Even while sitting on the seat, depending on how a person sits or posture, the sensors might have trouble detecting that person and automatic flushing might function.

Changing the timing of automatic flushing ► See page 42.  
Turning automatic flushing off ► See page 42.

### After urinating while standing

- Automatic flushing does not start unless standing up in front of the toilet for more than 6 seconds.
- "Light flushing" starts automatically about 3 seconds after urinating and moving about 30 cm or more away from the toilet.**

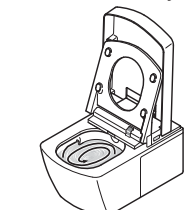

About 30 cm or longer

Tip 2

### How the body detection sensors work

- The body detection sensors detect when a person is standing in front of the toilet.
- The body detection sensors emit infrared rays as shown in the illustrations. These infrared rays allow the unit to detect when a person comes into their range.

#### Body detection sensor A

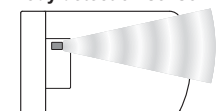

(When lid is closed)  
(When lid is open and seat is down)

#### Body detection sensor B

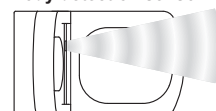

(When seat is up)

Tip 1

- Automatic flushing might not function if the sensors are unable to detect a small child or other person.
- Automatic flushing will not function for about 60 seconds after flushing once. Use the remote control buttons to flush.

Tip 2

- Automatic flushing might not function if the sensors are unable to detect a small child or other person depending on their position in front of the toilet, their height or other factor.
- Automatic flushing will not function for about 60 seconds after flushing once. Use the remote control buttons to flush.

# Energy Saver functions

The two Energy Saver functions include the Energy Saver timer and the Smart Energy Saver.

## Overview of the Energy Saver timer

**This is an Energy Saver that the owner can set.**

Once set, the seat heater will turn off automatically at the same time every day to conserve energy. The Energy Saver timer can be set to duration of 3, 6 or 9 hours.

► See pages 28 and 29 for how to use the Energy Saver timer.

Example:

Setting the Energy Saver to function from 1 to 7 a.m. (six hours)

1 At the time that you want the Energy Saver to start every day (1 a.m.), press **ENERGY SAVER**  on the remote control.

2 Select "6" for the Energy Saver time.

### Main display section

The seat heater turns off.

(Green)

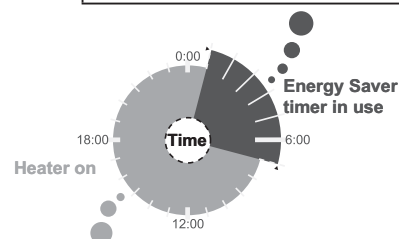

### Main display section

Operates at the set temperatures.

(Blue)



## Overview of the Smart Energy Saver

**This is an energy conservation function that is set automatically by the NEOREST.**

The NEOREST remembers the time periods when the toilet is used and determines the time periods when it is not used much in order to lower the seat temperature automatically and conserve energy.

► See page 30 for how to use the Smart Energy Saver.

Example:

When nobody is home between 9:30 a.m. and 7:00 p.m.

1 Press **ENERGY SAVER**  on the remote control.

The seat temperature is automatically lowered to conserve energy.

### Main display section

The seat temperature is lowered.

(Orange)

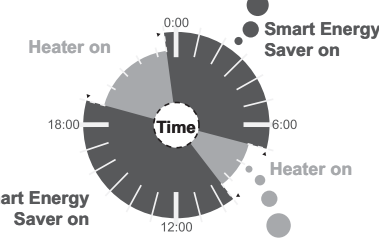

### Main display section

Operates at the set temperatures.

(Blue)



## The Energy Saver timer and the Smart Energy Saver can be used together

The Smart Energy Saver functions when the Energy Saver timer is not operating to increase energy conservation.

For example, they can be used together in the following manner to conserve energy.

How to use them together ► See page 31.

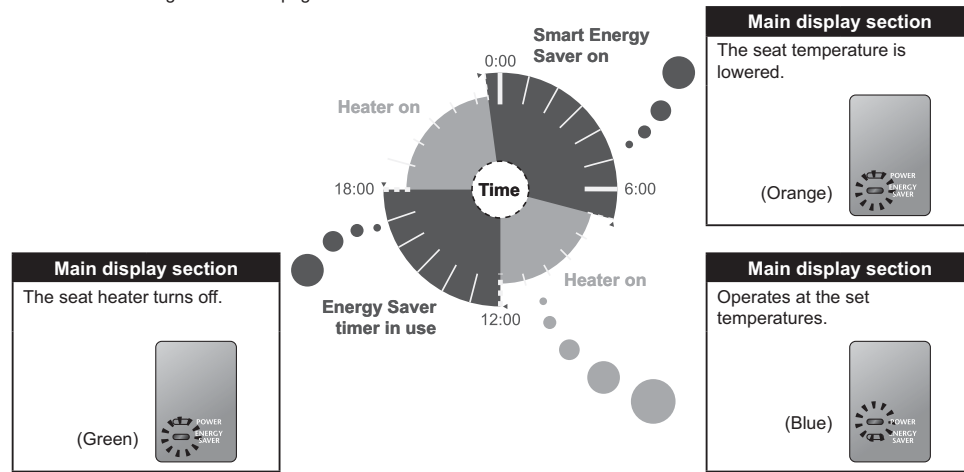

### Using the Energy Saver timer

#### Conserving energy using the Energy Saver timer

Example:

Follow these steps to set Energy Saver to turn off the heaters from 1 a.m. to 7 a.m. (six hours)

- At the time that you want the Energy Saver timer to start every day (1 a.m.), press **ENERGY SAVER**  on the remote control.

The Energy Saver starts.

- "3" appears on the remote control display.

Tip  1

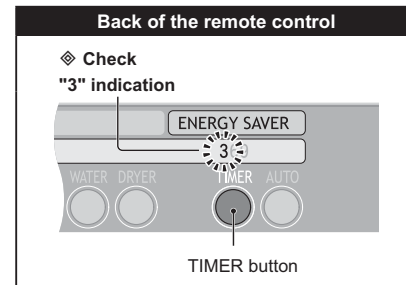

Tip  1

The seat heater can still be used when the Energy Saver timer is active.

- Even when the Energy Saver timer is active, sitting on the seat will turn the seat heater on temporarily.
- It takes about 15 minutes for the seat to warm up.
- It takes about 10 minutes for the water to become warm.

- Press **ENERGY SAVER**  to set it to 6 hours.

The setting is complete.

- When the Energy Saver timer is working, the "ENERGY SAVER" indicator in the main display section lights green.

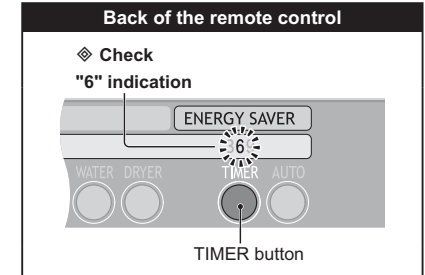

◆ Check here

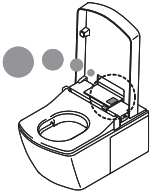
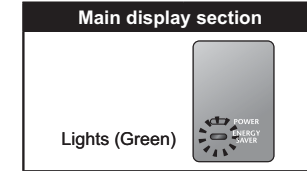

Operation

#### Changing the Energy Saver duration

- This can be set to 3, 6 or 9.

- Press **ENERGY SAVER**  on the remote control.

- Each press of the button cycles through the settings 3, 6, 9 and off (nothing appears on the display when off). Select the setting for the duration you want.

The setting change is complete.

- \* When you want to change the duration setting (3, 6 or 9 hours), reset the Energy Saver at the starting time you desire.

Tip  2

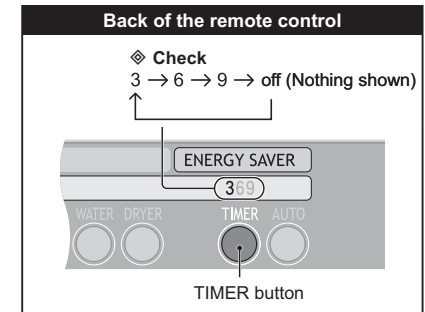

Tip  2

- When you want to change the Energy Saver starting time, after turning the Energy Saver timer off once, press **ENERGY SAVER**  again at the time you want it to start.

## Turning off the Energy Saver timer

- 1 Press **ENERGY SAVER**  on the remote control repeatedly until no time duration is shown.

The Energy Saver timer is turned off.

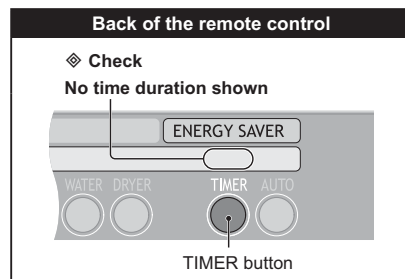

- The "POWER" indicator lights in the main display section.

◆ Check here

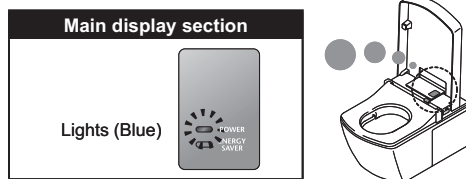

## Turning the Smart Energy Saver off

- 1 Press **ENERGY SAVER**  on the remote control.

- "●" disappears on the remote control display.

The Smart Energy Saver turns off.

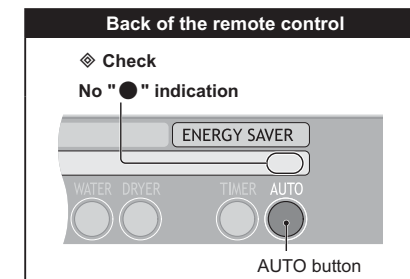

- The "POWER" indicator in the main display section will light blue.

◆ Check here

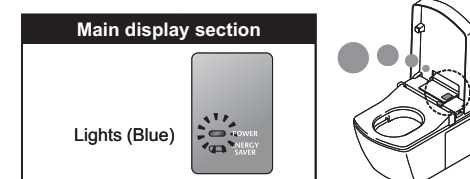

## Using the Smart Energy Saver

### Turning the Smart Energy Saver on

- 1 Press **ENERGY SAVER**  on the remote control.

- "●" appears on the remote control display.

The seat temperature is lowered automatically to start conserving energy.

Tip  1

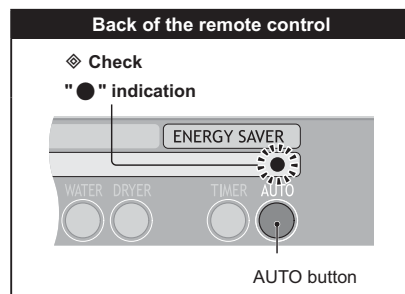

- During periods when the toilet is not used frequently, the "ENERGY SAVER" indicator in the main display section will light orange.

◆ Check here

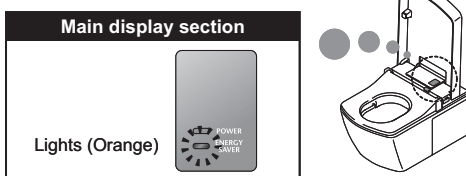

### Using the Energy Saver Timer and the Smart Energy Saver together

- The order that the buttons are pressed is not important.

- 1 At the time that you want the Energy Saver timer to start, press **ENERGY SAVER**  on the remote control.

- ▶ See pages 28 and 29 for how to use the Energy Saver timer.

- 2 Press **ENERGY SAVER** .

- ▶ See page 30 for how to use the Smart Energy Saver.

Tip  1

- It takes 2–3 days for the unit to identify times when the toilet is not used much. The Energy Saver will gradually take effect during this initial adjustment period.
- The heater can be used even when the Smart Energy Saver is operative.
  - When the Smart Energy Saver is on, the seat temperature is set to about 26°C, but the seat will warm temporarily when someone sits on it.

# Cleaning the NEOREST

Each part can be detached, allowing thorough cleaning

## Attention!

Always disconnect the mains plug from the socket when cleaning.  
\* Use of the "WAND CLEANING button" is an exception to this rule.

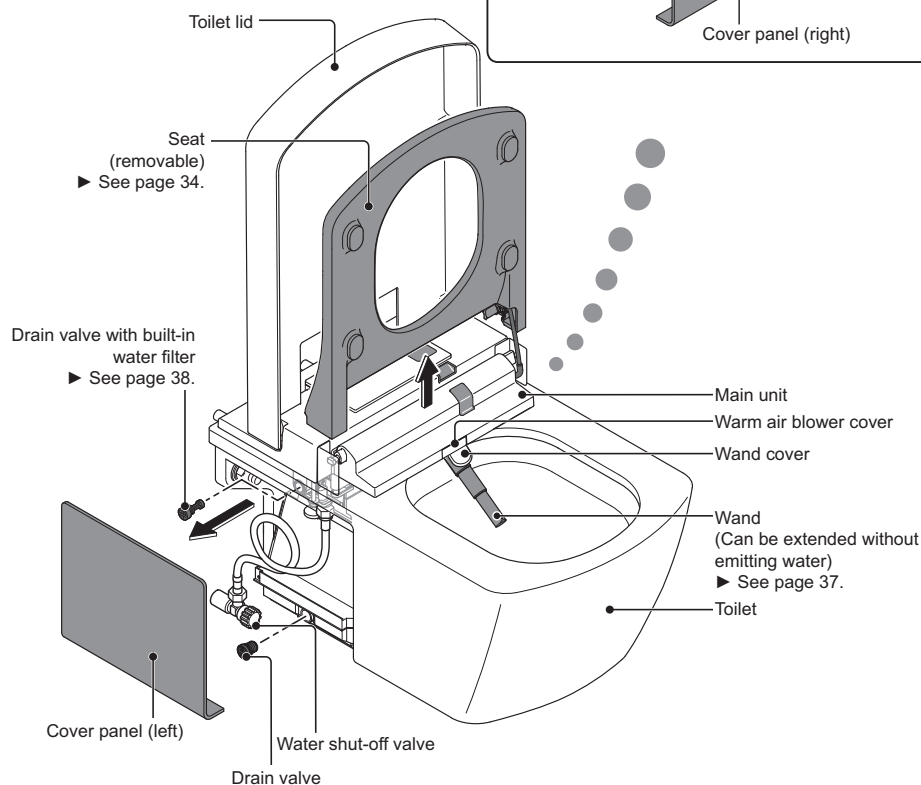
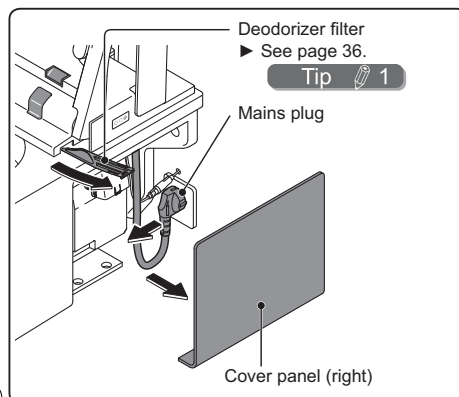

## Tip 1

- Since the amount of unevenness around the wand is reduced, the deodorizer filter can be kept in the main unit during cleaning. However, it can be removed for cleaning if odour becomes bothersome.

## Daily cleaning

### Cleaning the main unit, seat and lid

#### 1 Wipe with a soft wet cloth.

- After wetting a soft cloth with water, wring it out thoroughly and then use it to wipe the NEOREST.

#### Tip 2

- We have eliminated unevenness in the area around the wand, which tended to get dirty in previous models, to make it easy to wipe clean. Clean it after opening the seat and lid, being sure to put the deodorizer filter in its place first.
- \* Do not press or pull the wand cover or warm air blower cover with unnecessary force. (Doing so could cause damage or malfunction.)

#### Cleaning when the NEOREST is very dirty

- Wipe with a soft cloth dampened with diluted kitchen cleanser (pH neutral).
- After cleaning with the cleanser, wipe again with clean water.

#### Wipe away any toilet cleanser that spills on the NEOREST

- After wiping with a soft cloth dampened with water, wipe away any remaining droplets.

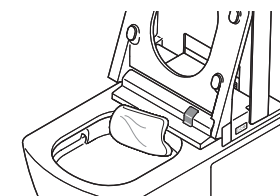
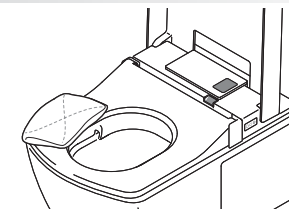

#### Cleaning the toilet

- Use a toilet brush or sponge and clean with water.

#### Cleaning the floor

- Use a rag that has been wrung to remove excess moisture to wipe up urine splashes outside the toilet and condensation that has fallen from the unit to the floor.
- \* Urine splashes sometimes occur when a person stands while urinating. This can be reduced by sitting down on the seat.
- When cleaning, be sure to wipe up cleaning chemicals and water that might have fallen on the floor using a rag that has been wrung to remove excess moisture.

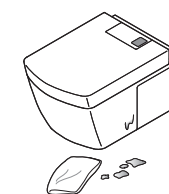
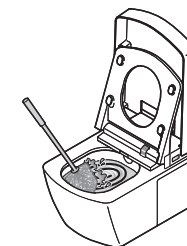

## Attention!

- When cleaning inside the toilet with toilet cleanser or similar substances, flush away the cleaning substances as quickly as possible (within three minutes), and then leave the seat and lid open. In addition, be sure to completely remove any cleanser remaining on the toilet. (If vapours from toilet cleansers or similar substances enter the main unit, this could lead to malfunction.)

## Tip 2

- Since the NEOREST is made of plastic, do not wipe it with a dry cloth, toilet paper or any similar material. Doing so could cause scratches. This could also reduce the ability of the inside of the seat and the wand to repel dirt.
- The NEOREST is an electric appliance. Be very careful to avoid letting water get inside it. Thoroughly wipe away any cleanser left in gaps between the main unit and the toilet.
- Keep the seat sensor, body detection sensors, remote control signal transmitter and signal receiver clean! Various functions may stop working if they become dirty.  
▶ See pages 10, 11, 13 and 49–59.

## Thorough cleaning

### Cleaning the main unit and seat

- The seat can be detached, allowing thorough cleaning.

### Detaching the seat

#### 1 Disconnect the mains plug.

- \* For your safety, disconnect the mains plug before removing the unit. In addition, avoid splashing water on the disconnected mains plug.
- The mains plug is behind the right cover panel. Removing the cover panel ▶ See page 16.

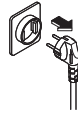

#### 2 Detach the seat.

Raise the seat and pull straight up as shown in the illustration.

- \* Detach the seat by grasping it with both hands and lifting.
- \* Do not pull up at an angle or use unnecessary force. (Doing so could cause damage.)

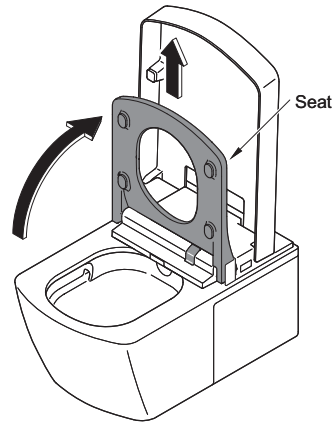
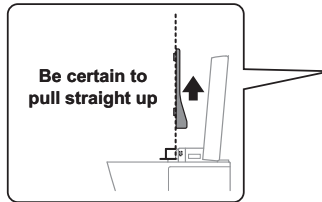

#### 3 Place the detached seat on top of the toilet.

- \* The length of the seat cord is about 8 cm. Do not pull it with excessive force. (Doing so could break the cord.)

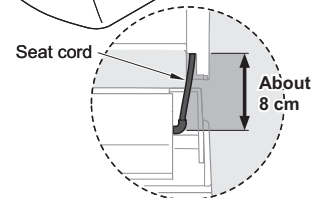
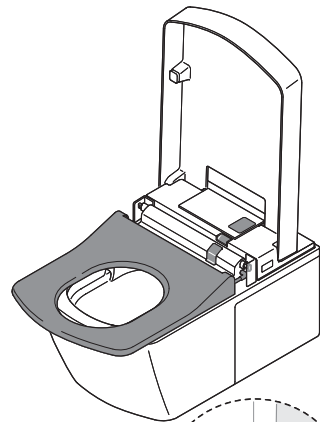

#### 4 Clean the main unit and seat.

"Cleaning the NEOREST" ▶ See page 32.

## Reattaching the seat

#### 1 Confirm that the seat pin is oriented vertically.

- \* If it is not, use pliers or a similar tool to orient it vertically.

Confirm that the seat pin is inserted completely with a vertical orientation.

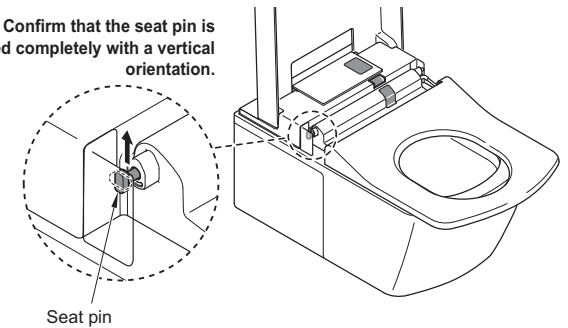

#### 2 Reattach the seat.

With the seat raised, push it onto the seat pin as shown in the illustration.

- \* Attach the seat by grasping it with both hands.
- \* Do not push the seat in diagonally or with excessive force.
- \* Make sure the seat cord is not twisted when you reattach the seat and lid.

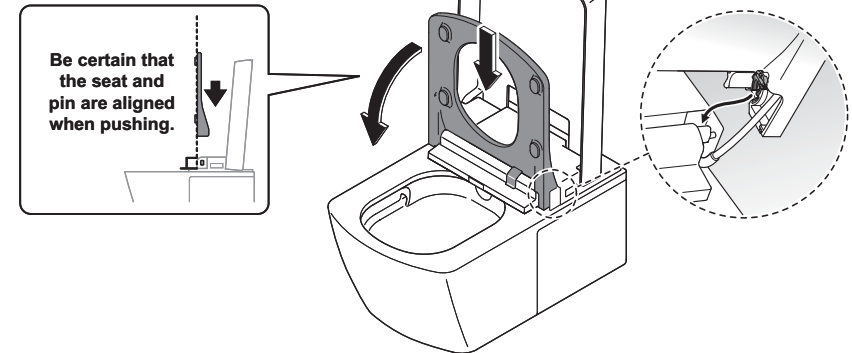

#### 3 Reconnect the mains plug.

Attaching the cover panel ▶ See page 16.

- The toilet flushing starts automatically.

## Periodic cleaning

### Cleaning the mains plug

- Clean the mains plug about once per month.

#### 1 Disconnect the mains plug.

- The mains plug is behind the right cover panel. Removing the cover panel ► See page 16.

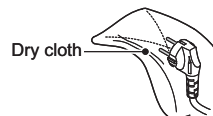

#### 2 Clean the plug.

- Remove dust from the blades and other parts of the mains plug with a dry cloth.

#### 3 Reinsert the mains plug.

- Insert the plug completely. Attaching the cover panel ► See page 16.
- The toilet flushing starts automatically.

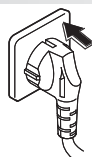

### Cleaning the deodorizer filter

- If the deodorizer does not seem to be clearing unpleasant smells, clean the deodorizer filter.

#### 1 Use a finger to pull the deodorizer filter out by its small handle.

- Do not pull it with excessive force. (Doing so could cause damage or malfunction.)

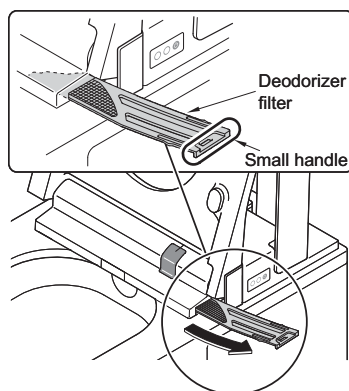

#### 2 Clean the unit.

- Remove the debris on the filter with a toothbrush or similar tool.

Tip 1

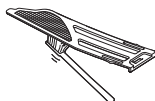

#### 3 Push the deodorizer filter back in.

- Push the deodorizer filter in completely.

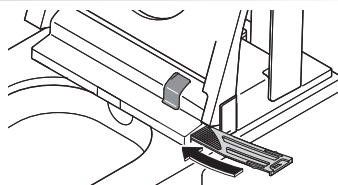

Tip 1

- The filter can be washed with water, but it should be dried before being reinstalled.
- Do not use brushes made of metal or other hard materials.

### Cleaning the wand

- The wand extends, making it easy to clean.

#### 1 Press on the remote control.

The wand extends.

- Warm water for cleaning comes out of the base of the wand.
- The wand automatically returns to its inactive position after about 5 minutes.

Back of the remote control

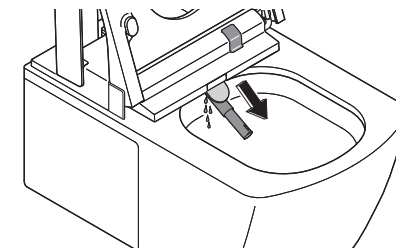

#### 2 Clean the unit.

- Wipe the wand with a soft damp cloth.
- \* Do not push, press or pull the wand with excessive force. (Doing so could cause damage or malfunction.)

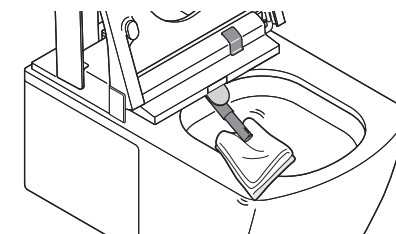

#### 3 Press again.

The wand retracts and automatically emits water to clean itself.

Tip 2

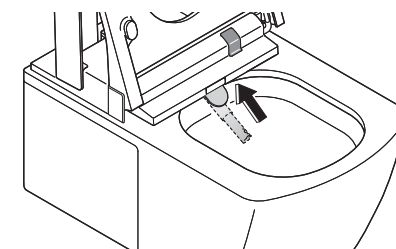

Tip 2

- When the seat is closed or when the seat is closed after wand cleaning, the wand will retract once and then come out again to remove remaining water. The wand retracts again after about 30 seconds.



## Cleaning the drain valve with built-in water filter

- Clean the drain valve with built-in water filter if the water pressure during rear or front washing seems to have weakened.

### 1 Remove the cover panel (left).

Removing the cover panel ▶ See page 16.

### 2 Close the water shut-off valve and stop the water supply.

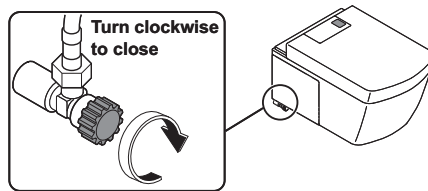

### 3 Detach the drain valve with built-in water filter.

- (1) Press and extend the wand, and then press again. (This removes the pressure in the water pipes.)
- (2) Use a flat-blade screwdriver to loosen the drain valve with built-in water filter and then pull it out.

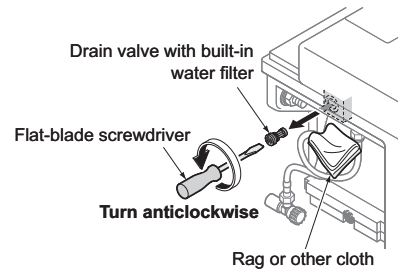

#### CAUTION



Do not detach the drain valve with built-in water filter while the water shut-off valve is still open.

- Doing so will cause water to spill.

### 4 Clean the drain valve with built-in water filter.

- Thoroughly remove the debris on the filter with a toothbrush or similar tool.
- Use a cotton swab or similar to remove debris from inside the attachment hole for the drain valve with built-in water filter.

Tip 1



### 5 Reattach the drain valve with built-in water filter.

- Insert the drain valve with built-in water filter and use a flat-blade screwdriver to tighten it thoroughly.

#### CAUTION



Thoroughly tighten the drain valve with built-in water filter.

- Failure to do so could cause a water leak.

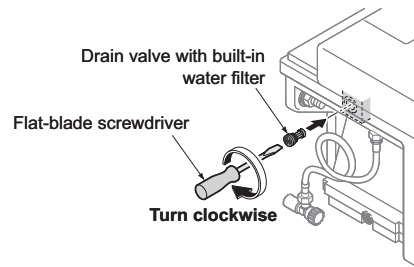

### 6 Open the water shut-off valve.

### 7 Reattach the cover panel (left).

Attaching the cover panel ▶ See page 16.

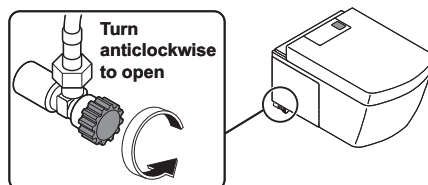

Tip 1

#### Cleaning the water filter

- Do not use cleanser. Wash with plain water.
- Do not break the water supply filter or detach it from the drain valve.

## Changing settings

Before changing other settings, follow the instructions in the next section, "Setting whether or not the remote control makes sound" to turn the sound on if it is currently off. You will use this sound to confirm changes to other settings.

### Remote control sound

#### Setting whether or not the remote control makes sound

By default, when you press a remote control button, you will hear a sound when the main unit receives the signal.

You can choose to turn this confirmation sound off.

Default setting: **Sound on**

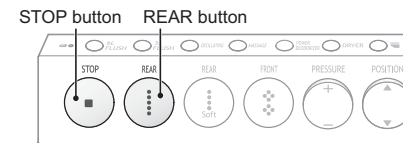

### 1 Press for at least 10 seconds.

- Hold the button down until the whole remote control display blinks.

#### Back of the remote control

##### Check

All the indicators on the remote control display section blink

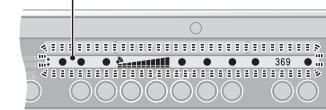

### 2 Press for at least 5 seconds.

- The setting changes every time the button is pressed for at least 5 seconds.
  - **To turn the sound ON:**  
Press the button until you hear a short beep.
  - **To turn the sound OFF:**  
Press the button until you hear a long beep.

### 3 Press again.

This completes the change to the settings.

### Automatic opening and closing

#### Setting whether or not automatically open and close the lid

Default setting: **on (opens and closes automatically)**

#### Back of the remote control

OPEN/CLOSE button

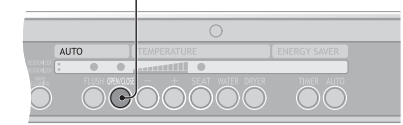

### 1 Press .

#### Back of the remote control

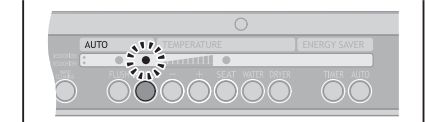

- Each time you press the setting changes between ON and OFF.
- **To turn automatic opening and closing on:**  
Make the "●" appear in the display section on the back of the remote control.
- **To turn automatic opening and closing off:**  
Turn "●" off on the remote control display.

This completes the change to the settings.

## Automatic opening and closing

### Changing the amount of time before the seat and lid closes

The delay until closing can be set to about 90 seconds or about 6 seconds.

**Default setting:** about 90 seconds

STOP button

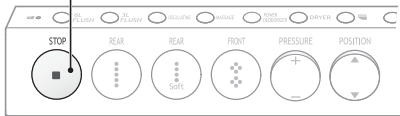

Back of the remote control

OPEN/CLOSE button

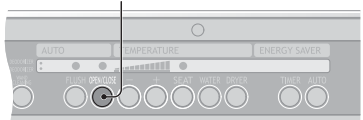

### 1 Press for at least 10 seconds.

- Hold the button down until the whole remote control display blinks.

Back of the remote control

Check

All the indicators on the remote control display section blink

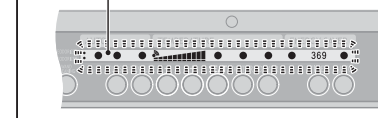

### 2 Press for at least 5 seconds.

- The setting changes every time the button is pressed for at least 5 seconds.
- **To set the delay to about 90 seconds:**  
Press the button until you hear a long beep.
- **To set the delay to about 6 seconds:**  
Press the button until you hear a short beep.

### 3 Press again.

This completes the change to the settings.

## Automatic opening and closing

### Opening the lid/opening the seat and lid automatically

\* Whether or not the lid opens and closes automatically can be set.

**Default setting:** only the lid opens automatically

STOP button

Seat and lid open button

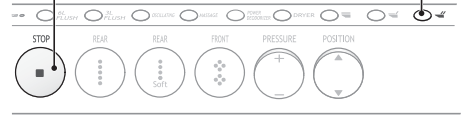

### 1 Press for at least 10 seconds.

- Hold the button down until the whole remote control display blinks.

Back of the remote control

Check

All the indicators on the remote control display section blink

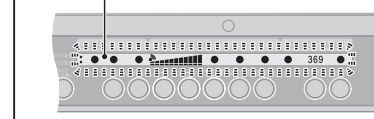

### 2 Press .

- Each time you press the setting changes between ON and OFF.
- **To have the lid open automatically:**  
Press the button until you hear a long beep.
- **To have both the seat and lid open automatically:**  
Press the button until you hear a short beep.

### 3 Press again.

This completes the change to the settings.

## Standard Deodorizer

### Setting automatic operation of the standard deodorizer

Whether or not the deodorizer operates while a person is seated on the seat can be set.

**Default setting:** ON

STOP button POWER DEODORIZER button

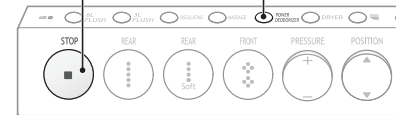

### 1 Press for at least 10 seconds.

- Hold the button down until the whole remote control display blinks.

Back of the remote control

Check

All the indicators on the remote control display section blink

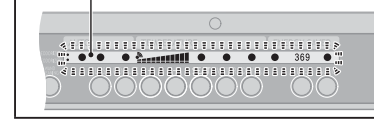

### 2 Press .

- Each time you press the setting changes between ON and OFF.
- **To turn automatic operation of the standard deodorizer ON:**  
Press the button until you hear a short beep.
- **To turn automatic operation of the standard deodorizer OFF:**  
Press the button until you hear a long beep.

### 3 Press again.

This completes the change to the settings.

## Automatic Power Deodorizer

### Setting automatic use of the Power Deodorizer

**Default setting:** ON

STOP button

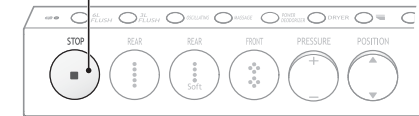

Back of the remote control

SEAT button

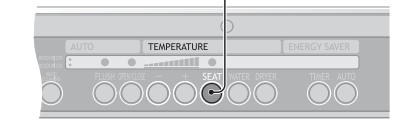

### 1 Press for at least 10 seconds.

- Hold the button down until the whole remote control display blinks.

Back of the remote control

Check

All the indicators on the remote control display section blink

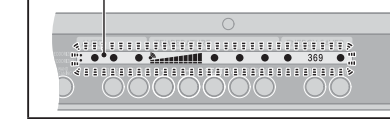

### 2 Press .

- Each time you press the setting changes between ON and OFF.
- **To turn automatic operation of the Power Deodorizer ON:**  
Press the button until you hear a short beep.
- **To turn automatic operation of the Power Deodorizer OFF:**  
Press the button until you hear a long beep.

### 3 Press again.

This completes the change to the settings.

## Automatic flushing

### Setting automatic flushing

Default setting: ON

#### Back of the remote control

FLUSH button

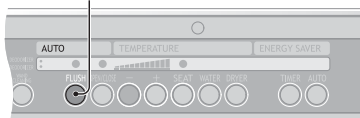

1 Press .

#### Back of the remote control

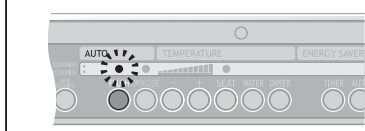

- Each time you press the setting changes between ON and OFF.
- **To make the toilet flush automatically:**  
Make the "●" appear in the display section on the back of the remote control.
- **To make the toilet not flush automatically:**  
Make the "●" disappear in the display section on the back of the remote control.

This completes the change to the settings.

## Automatic flushing

### Setting the delay until the automatic flushing starts

The delay before automatic flushing can be set to about 5 seconds (when the seat is used) or about 10 seconds.

Default setting: about 5 seconds

STOP button POSITION button

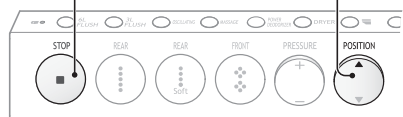

1 Press  for at least 10 seconds.

- Hold the button down until the whole remote control display blinks.

#### Back of the remote control

##### Check

All the indicators on the remote control display section blink

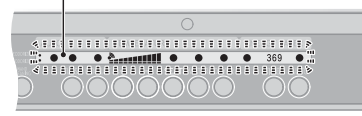

2 Press  "▲".

- Each time you press the setting changes between ON and OFF.
- **To make the delay about 5 seconds:**  
Press the button until you hear a long beep.
- **To make the delay about 10 seconds:**  
Press the button until you hear a short beep.

3 Press  again.

This completes the change to the settings.

## Water pressure and washing position

### Making the unit remember the last water pressure and washing position settings

The unit can be set to remember the last water pressure and washing positions used.

STOP button REAR(Soft) button

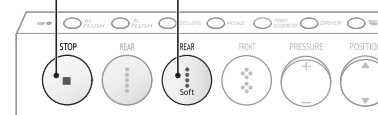

1 Press  for at least 10 seconds.

- Hold the button down until the whole remote control display blinks.

#### Back of the remote control

##### Check

All the indicators on the remote control display section blink

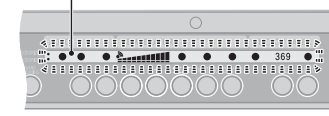

2 Press  for at least 5 seconds.

3 Press  again.

This completes the change to the settings.

- To restore the previous settings, repeat the above procedures.

# Responding to power cuts and water outages

## When a power cut or water outage occurs

- If a power cut or water outage occurs, water will stop flowing in the toilet. Respond to the problem according to the circumstances as follows.

### When the power is cut

#### Flushing the toilet when there is a power cut

- Press the flush panel button to flush the toilet with water.

(1) Press the flush panel button.

The toilet flushing starts.

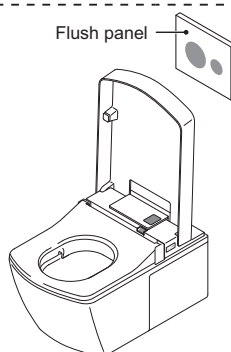

### When there is a water outage

Tip 1

- Fill a large bucket with water (about eight litres) and pour it into the centre of the toilet bowl and flush. When doing this, be careful not to allow water to overflow out of the toilet bowl.

Tip 2

- Add water if the water level in the toilet bowl is low after flushing. This blocks odours from the toilet plumbing.

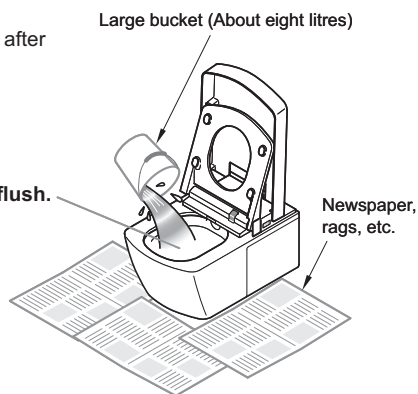

Tip 1

- If there is a water outage, turn automatic flushing off. Turning off the automatic flushing ▶ See page 42.

Tip 2

- Place newspaper or another absorbent material around the toilet to prevent the floor from becoming wet.



# Preventing damage from freezing and measures for long-term disuse

## Preparation for freezing conditions

Tip 3

- Keep the toilet warm, so that the temperature stays above freezing. If this is not possible, drain the water.
- If you worry that the water might freeze, follow these procedures to prevent damage to the NEOREST.
- If the NEOREST freezes, it might suffer damage and water leaks could occur.

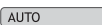
### Attention!

- Before conducting these procedures to prevent freezing, turn **AUTO**  and **FLUSH**  and **OPEN/CLOSE**  to "off", then lower the toilet seat and close the lid.

### Draining the water

1 Close the water shut-off valve.

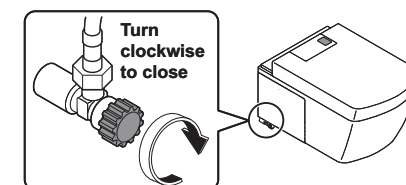

2 Drain the water from the NEOREST pipes.

(1) Press  and extend the wand, and then press  again.

(This removes the pressure in the water pipes.)

(2) Remove the cover panel (left).  
Removing the cover panel ▶ See page 16.

(3) Use a flat-blade screwdriver to loosen the drain valve with built-in water filter and then pull it out.

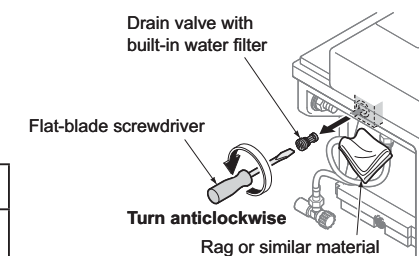

### CAUTION

-  Do not detach the drain valve with built-in water filter while the water shut-off valve is still open.
- Doing so will cause water to spill.

(4) After draining the water, insert the drain valve with built-in water filter and use a flat-blade screwdriver to tighten it thoroughly.

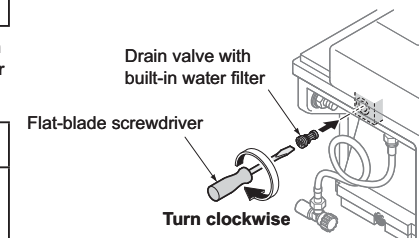

### CAUTION

-  Thoroughly tighten the drain valve with built-in water filter.
- Failure to do so could cause a water leak.

Tip 3

### Preparation for freezing conditions

- Do not use the Energy Saver. The NEOREST could be damaged if the water freezes when the heaters are turned off. Turning off the Energy Saver timer ▶ See page 30. Turning the Smart Energy Saver off ▶ See page 31.

### 3 Drain the water from the NEOREST.

- (1) Use a flat-blade screwdriver to loosen the drain valve and pull it out.
- About 1000 ml of water will come out of the drain valve opening. This water takes about 60 seconds to be completely drained.

- (2) After draining the water, insert the drain valve and use a flat-blade screwdriver to tighten it thoroughly.

- (3) Attach the cover panel (left).  
Attaching the cover panel ▶ See page 16.

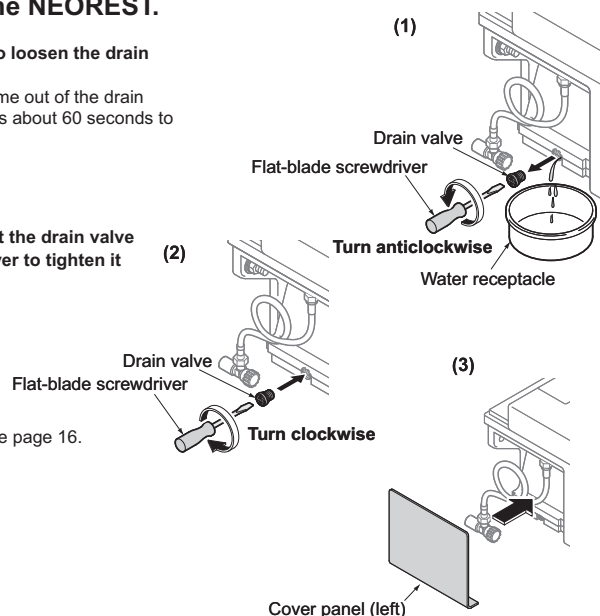

### 4 Keep the inside of the main unit warm.

- (1) Confirm that  in the main operation section is "on" and use the remote control to set high warm water and seat temperature levels.

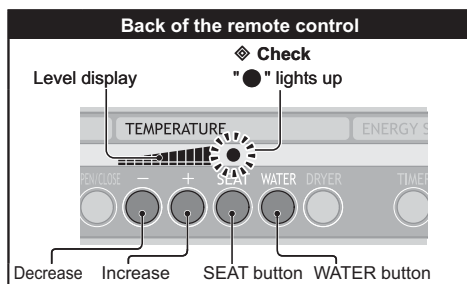
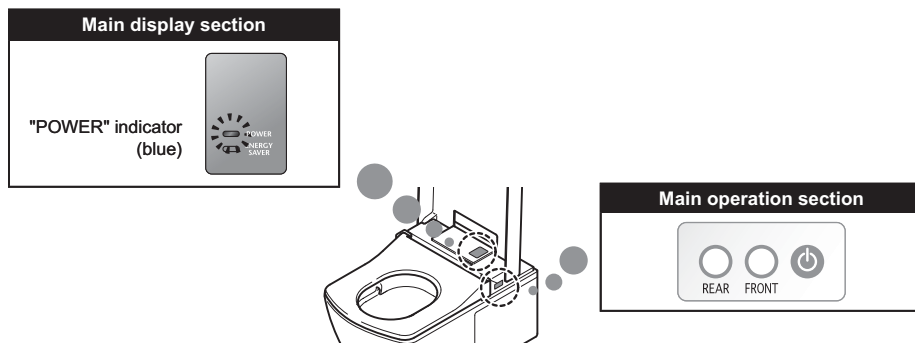

### What to do if you will not use the NEOREST for a long time

- Water left in the unit could become contaminated and cause skin inflammation or other problems. You should also drain the water to prevent the NEOREST from damaging.

Tip  1

#### Draining the water

##### 1 Close the water shut-off valve.

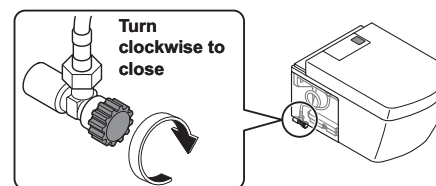

##### 2 Drain the water from the NEOREST pipes.

- ▶ See step 2 of "Draining the water" on page 45.

##### 3 Drain the water from the NEOREST.

- ▶ See step 3 of "Draining the water" on page 46.

##### 4 Disconnect the mains plug.

- The mains plug is behind the right cover panel.  
Attaching and removing the cover panel ▶ See page 16.

##### 5 Treat the water remaining in the toilet.

Tip  2

Tip  1

#### Do not forget to drain the water!

- When leaving home for a long time in the winter.
- When the NEOREST is installed in a vacation home or other location that is not always occupied. Empty homes can be very cold in winter.

Tip  2

- Put antifreeze in the water remaining in the toilet to reduce the chance of freezing.

## Restoring the water supply after draining the NEOREST

### 1 Open the water shut-off valve.

- \* Check that no water is leaking from pipes or the main unit.

### 2 Insert the mains plug in the socket.

- The mains plug is behind the right cover panel.
- Attaching and removing the cover panel ► See page 16.
- The toilet flushing starts automatically.

### 3 Run water through the wand.

- Cover the seat sensor with white paper and press  on the remote control to make water flow through the wand for about 2 minutes. (It takes about one minute to discharge the water from the wand. Catch the water in a cup.)
- The switch will not respond for about 10 seconds after inserting the mains plug in the socket.

## Troubleshooting

Please read this section to troubleshoot any problem before requesting repairs. If you still cannot solve the problem after reviewing this section, please contact TOTO Europe GmbH (see the back cover for contact information).

### ⚠ CAUTION

If a water leak occurs, close the water shut-off valve and stop the water supply.



Required

Turn clockwise to close

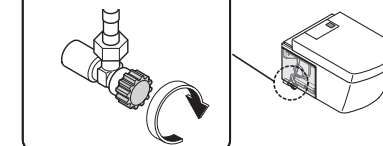

Please confirm the following points before requesting repair.

### Check these first!

#### Is the NEOREST "POWER" indicator in the main display section lit?

- Is the "POWER" indicator lit? ► See page 17.

→ If the "POWER" indicator is lit

Proceed to the following section: "Is the remote control working?"

→ If the "POWER" indicator is not lit

- Are other indicators lit even though the "POWER" indicator is not lit?
  - If other indicators are lit, the Energy Saver might be operative. ► See page 27.
- Are all indicators unlit?
  - Follow these steps to see if the indicators light.

1. Insert the mains plug in the socket.
2. Has there been a power cut or are any of the central power breakers switched off?
 

Wait until the power has been restored.  
If the breaker controlling the power to the NEOREST is off, turn it back on.
3. Press  in the main operation section.

◆ Check here

#### Main display section

Lights

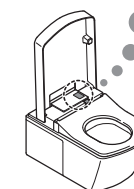

#### Is the remote control working?

- Have all the indicators on the remote control LCD disappeared?
  - Check whether working batteries are properly installed.
- Is the low battery warning indicator on the remote control screen blinking?
  - If the batteries are running out of power, replace them with new ones. ► See page 14.
- Is the remote control signal transmission area covered or dirtied by debris or water droplets, for example?
  - Check the position of the remote control signal transmission area and remove or clean whatever is blocking the transmission window. ► See pages 11 and 13.

If the problem is not resolved after confirming the above points, continue with "Identifying the problem" on the next page.



## Identifying the problem

### Rear wash, soft wash, front wash or warm air dryer does not work

Trouble	
REAR REAR FRONT or DRYER on the remote control does not work.	
Tests and results	Solutions
Do REAR FRONT on the main unit work? * If the seat sensor does not detect a person, these functions will not work. Please sit on the seat when confirming these operations.	<b>If it works</b> <ul style="list-style-type: none"> <li>The remote control signal might not be being received.</li> </ul> <b>If it is not working</b> <ul style="list-style-type: none"> <li>Follow the instructions in "Is the remote control working?" to check whether it is working.               <ul style="list-style-type: none"> <li>▶ See page 49.</li> </ul> </li> <li>Conditions might be preventing the seat sensor from functioning properly. Is the seat sensor covered or dirtied by debris or water droplets, for example? Check the position of the seat sensor and remove or clean whatever is blocking it.               <ul style="list-style-type: none"> <li>▶ See pages 10 and 19.</li> </ul> </li> <li>The seat sensor might not work depending on how a person sits or the colour and fabric of their clothing. Sit on the seat fully and raise clothing so that the sensor can detect skin.</li> </ul>
Does the wand extend when you press the remote control REAR REAR FRONT or other buttons?	<b>If the wand extends but washing water does not come out or is very weak</b> <ul style="list-style-type: none"> <li>Water might not be supplied to the NEOREST.</li> </ul> <b>If the wand does not extend</b> <ul style="list-style-type: none"> <li>The seat sensor might be continuously detecting the presence of a person, causing it to retract as a safety measure.</li> <li>If a person sits continuously for about two hours, rear wash, front wash and soft wash stop operating as a matter of safety. Leave the seat once and then sit down to use these functions again.</li> <li>If water droplets or grime are on the seat sensor, the seat sensor might falsely detect the continuous presence of a person. Check the position of the seat sensor and remove or clean whatever is blocking it.               <ul style="list-style-type: none"> <li>▶ See pages 10 and 19.</li> </ul> </li> <li>If the seat sensor is covered by a plastic bag or similar materials, for example, the seat sensor might falsely detect the continuous presence of a person. False detection might also occur if a seat or lid cover or an infant seat is attached and left on the unit. Remove the seat or lid cover or whatever is covering the seat sensor. Always remove infant seats, for example, after using them.</li> </ul> <b>If the wand does not extend</b> <ul style="list-style-type: none"> <li>Have you been using it continuously? Rear, soft and front washing stop automatically about 5 minutes after pressing the button. The indicator in the main display section blinks for about a minute while water is being warmed.</li> </ul>

### Flushing does not work

Trouble	
The toilet flushing does not start.	
Tests and results	Solutions
<b>Does the toilet flushing start by using the remote control?</b>	<b>If the toilet flushing does not start</b> <ul style="list-style-type: none"> <li>Water might not be supplied to the toilet.</li> </ul> <ul style="list-style-type: none"> <li>Is the water off? Wait for the water to turn on again. Even during a water outage, you can flush the toilet by pouring in water from a bucket, for example.               <ul style="list-style-type: none"> <li>▶ See page 44.</li> </ul> </li> <li>Is the water shut-off valve closed? Open the water shut-off valve fully.</li> </ul>
<b>Is the button being pressed continuously?</b>	<ul style="list-style-type: none"> <li>The 6L FLUSH/3L FLUSH button cannot be used continuously. It takes about ten seconds until it can be flushed again. Wait a moment and press the button again.</li> </ul>
Trouble	
Flushing does not happen automatically (automatic flushing fails).	
Tests and results	Solutions
<b>Does a "●" appear above "FLUSH" on the back of the remote control?</b>	<b>If "●" is lit</b> <ul style="list-style-type: none"> <li>Conditions might prevent the seat and body detection sensors from functioning properly. A sensor might also be falsely detecting the continuous presence of a person. Are debris or water droplets, for example, covering a seat or body detection sensor? Check the seat and body detection sensors and remove any dirt or grime.               <ul style="list-style-type: none"> <li>▶ See pages 10, 11, 19 and 26.</li> </ul> </li> <li>After automatic toilet flushing or flushing by remote control, automatic toilet flushing will not occur for about 60 seconds. Use the remote control to flush the toilet again during this period.</li> <li>If the amount of time spent sitting on the seat (or time spent standing in front of the toilet to urinate) is six seconds or less, the toilet will not flush automatically.               <ul style="list-style-type: none"> <li>▶ See page 26.</li> </ul>               In addition, check that conditions do not make it difficult for the seat and body detection sensors to detect a person.               <ul style="list-style-type: none"> <li>▶ See pages 10, 19 and 26.</li> </ul> </li> <li>Sometimes flushing does not occur automatically when a person is standing in front of the toilet. Move away from the toilet and wait about 3-5 seconds.               <ul style="list-style-type: none"> <li>▶ See page 26.</li> </ul>               In addition, check that conditions are not causing the seat and body detection sensors to falsely detect the continuous presence of a person.               <ul style="list-style-type: none"> <li>▶ See pages 10, 19 and 26.</li> </ul> </li> </ul>



Tests and results		Solutions
Does a "●" appear above "FLUSH" on the back of the remote control?	If "●" is unlit <ul style="list-style-type: none"> <li>Automatic flushing is off.</li> </ul>	<ul style="list-style-type: none"> <li>Press   on the remote control to turn automatic flushing on.</li> <li>▶ See pages 26 and 42.</li> </ul>

### Seat and lid opening/closing do not work



**Trouble** The seat and lid does not open or close.

Tests and results		Solutions
Can you open and close the seat and lid using the remote control?	<p><b>If the seat and lid does not open or close</b></p> <ul style="list-style-type: none"> <li>The seat might not be attached properly.</li> <li>Is the seat sensor covered or dirtied by debris or water droplets, for example?</li> </ul> <p><b>If the seat and lid does not open or close (but it still opens automatically)</b></p> <ul style="list-style-type: none"> <li>The remote control signal might not be being received.</li> </ul>	<ul style="list-style-type: none"> <li>Reattach the seat properly. <ul style="list-style-type: none"> <li>▶ See pages 34 and 35.</li> </ul> </li> <li>Remove or clean whatever is blocking it. <ul style="list-style-type: none"> <li>▶ See pages 10 and 19.</li> </ul> </li> </ul> <p>Follow the instructions in "Is the remote control working?" to check whether it is working.</p> <ul style="list-style-type: none"> <li>▶ See page 49.</li> </ul>

**Trouble** The lid does not open automatically (Automatic opening and closing).

Tests and results		Solutions
Does a "●" appear above "OPEN/CLOSE" on the back of the remote control?	<p>If "●" is lit</p> <ul style="list-style-type: none"> <li>Are conditions preventing body detection sensor A from working properly? Remove any plastic bag, tape or other obstruction that might be covering body detection sensor A. Likewise, clean away debris, water droplets or similar substances. <ul style="list-style-type: none"> <li>▶ See page 26.</li> </ul> </li> <li>If you close the lid by the remote control or hand, the lid does not open automatically for about 10 seconds. Approach the toilet after about 10 seconds and the lid will open automatically.</li> </ul> <p>If "●" is unlit</p> <ul style="list-style-type: none"> <li>The automatic opening and closing function is off.</li> </ul>	<ul style="list-style-type: none"> <li>Press   on the remote control and turn it on. <ul style="list-style-type: none"> <li>▶ See pages 24 and 39.</li> </ul> </li> </ul>

**Trouble** The seat and lid does not close automatically (Automatic opening and closing).

Tests and results		Solutions
Does a "●" appear above "OPEN/CLOSE" on the back of the remote control?	<p>If "●" is lit</p>	<ul style="list-style-type: none"> <li>The seat and lid do not close automatically if you stand up in front of the toilet. Move away from the toilet and wait about 90 seconds. <ul style="list-style-type: none"> <li>▶ See page 25.</li> </ul> </li> <li>If water droplets or grime are on the seat and body detection sensors, the sensors might falsely detect the continuous presence of a person. Clean everything off the sensor. <ul style="list-style-type: none"> <li>▶ See pages 10, 11, 19 and 26.</li> </ul> </li> </ul>
	<p>If "●" is unlit</p> <ul style="list-style-type: none"> <li>The automatic opening and closing function is off.</li> </ul>	<ul style="list-style-type: none"> <li>Press   on the remote control and turn it on. <ul style="list-style-type: none"> <li>▶ See pages 24 and 39.</li> </ul> </li> </ul>







### The deodorizer and Energy Saver do not work



**Trouble** The deodorizer does not function.

Tests and results		Solutions
The deodorizer might be set to "off".		<ul style="list-style-type: none"> <li>Set the deodorizer to "on". <ul style="list-style-type: none"> <li>▶ See page 41.</li> </ul> </li> </ul>
Can you hear the sound of the deodorizer operating when you sit on the seat?	<p><b>If there is no deodorizer sound</b></p> <ul style="list-style-type: none"> <li>Conditions might be preventing the seat sensor from functioning properly. Is the seat sensor covered or dirtied by debris or water droplets, for example?</li> </ul> <p><b>If there is no deodorizer sound</b></p> <ul style="list-style-type: none"> <li>The seat sensor might not work depending on how a person sits or the colour and fabric of their clothing.</li> </ul>	<ul style="list-style-type: none"> <li>Check the position of the seat sensor and remove or clean whatever is blocking it. <ul style="list-style-type: none"> <li>▶ See pages 10 and 19.</li> </ul> </li> <li>Sit on the seat fully and raise clothing so that the sensor can detect skin.</li> </ul>

Tests and results		Solutions
Can you hear the sound of the deodorizer operating when you sit on the seat?	If there is deodorizer sound <ul style="list-style-type: none"> <li>The deodorizer filter might be blocked.</li> </ul>	<ul style="list-style-type: none"> <li>Clean the deodorizer filter. <ul style="list-style-type: none"> <li>▶ See page 36.</li> </ul> </li> </ul>
<b>Trouble</b> The Automatic Power Deodorizer does not work.		
Tests and results		Solutions
Does the Automatic Power Deodorizer work when you move away from the seat?	If it does not work, the "Automatic Power Deodorizer" setting on the remote control might be set to "off".	<ul style="list-style-type: none"> <li>Set the Automatic Power Deodorizer to "on". <ul style="list-style-type: none"> <li>▶ See page 41.</li> </ul> </li> </ul>
<b>Trouble</b> The Energy Saver timer and Smart Energy Saver have stopped working.		
Tests and results		Solutions
Have you changed the batteries in the remote control?	If you changed the batteries in the remote control, or the batteries have gone dead, these settings might be lost.	<ul style="list-style-type: none"> <li>Set the Energy Saver timer and Smart Energy Saver again. <ul style="list-style-type: none"> <li>▶ See pages 27-31.</li> </ul> </li> </ul>
<b>Trouble</b> The Smart Energy Saver does not work.		
Tests and results		Solutions
Does a "●" appear above "AUTO" on the back of the remote control?	If the Smart Energy Saver is set to "on", it will study use patterns over several days and determine the time periods that energy will be conserved, if any. Depending on the frequency of use, the Smart Energy Saver might not function for much time each day.	<ul style="list-style-type: none"> <li>Please read the "Energy Saver functions" section. <ul style="list-style-type: none"> <li>▶ See page 27.</li> </ul> </li> </ul>

## The seat, washing or warm air dryer temperature is too cold or too hot

<b>Trouble</b> The seat does not warm up (it is cold).		
Tests and results		Solutions
Check the display section on the back of the remote control.	Is the seat temperature setting low or off?	<ul style="list-style-type: none"> <li>Press  on the back of the remote control and adjust the temperature with  and .</li> <li>▶ See page 20.</li> </ul>
Is the main display section "ENERGY SAVER" indicator lit?	<p>If the green "ENERGY SAVER" indicator is lit</p> <ul style="list-style-type: none"> <li>The Energy Saver, which automatically turns the seat heater off, is active. (Energy Saver timer operative)</li> </ul> <p>If the orange "ENERGY SAVER" indicator is lit</p> <ul style="list-style-type: none"> <li>Energy is conserved and the seat temperature is lowered. (Smart Energy Saver operative)</li> </ul>	<ul style="list-style-type: none"> <li>Sitting on the seat temporarily starts the heater. It will become warm in about 15 minutes. <ul style="list-style-type: none"> <li>▶ See page 28 for information about the Energy Saver timer function.</li> </ul> </li> <li>The seat will be heated temporarily when someone sits on it. <ul style="list-style-type: none"> <li>▶ See page 30 for information about the Smart Energy Saver function.</li> </ul> </li> </ul>
Have you been sitting on the seat for 1 hour or longer?	If the seat sensor continuously detects a person for an hour or more, the seat heater turns off automatically as a safety measure.	<ul style="list-style-type: none"> <li>If you move away from the seat once, the seat heater will start again automatically.</li> </ul>
Is the seat sensor window dirty?		<ul style="list-style-type: none"> <li>Is the seat sensor covered or dirtied by debris or water droplets, for example? Remove or clean whatever is blocking it. <ul style="list-style-type: none"> <li>▶ See pages 10 and 19.</li> </ul> </li> </ul>
<b>Trouble</b> The rear or front washing water is cold.		
Tests and results		Solutions
Check the display section on the back of the remote control.	Is the water temperature setting low or off?	<ul style="list-style-type: none"> <li>Press  on the back of the remote control and adjust the temperature with  and .</li> <li>▶ See page 21.</li> </ul>
Is the water emitted cold only at first?		<ul style="list-style-type: none"> <li>If the temperature of the water supply or the room that the toilet is in is low, the water emitted at first might be cold.</li> </ul>

<b>Trouble</b> The warm air dryer is not warm enough.	
<b>Tests and results</b>	
Check the display section on the back of the remote control.	<p>Is the warm air temperature setting low?</p> <ul style="list-style-type: none"> <li>Press  on the back of the remote control and adjust the temperature with  and . ▶ See page 21.</li> </ul>

#### The rear and front washing water pressure is weak

<b>Trouble</b> The washing water pressure is weak.	
<b>Tests and results</b>	
Is the water pressure set to a low level?	<ul style="list-style-type: none"> <li>Use  on the remote control to adjust the temperature. ▶ See page 18.</li> </ul>
Is the water filter in the drain valve blocked?	<ul style="list-style-type: none"> <li>Clean the drain valve with built-in water filter. ▶ See page 38.</li> </ul>
Is the water shut-off valve closed?	<ul style="list-style-type: none"> <li>Turn the water shut-off valve anticlockwise. ▶ See pages 10 and 17.</li> </ul>

#### The rear wash, soft wash, front wash or warm air dryer starts unexpectedly or stops suddenly

<b>Trouble</b> The rear wash, soft wash, front wash or warm air dryer stops working suddenly.	
<b>Tests and results</b>	
Have you been using it for a long time?	<p>Rear, soft and front washing stop automatically about 5 minutes after pressing the button. The indicator in the main display section blinks for about a minute while water is being warmed.</p> <p>The warm air dryer stops about 10 minutes after pressing the button.</p>
Are you sitting in a way that prevents the seat sensor from working?	<ul style="list-style-type: none"> <li>If you get up slightly from the seat, or sit forward on the seat, the seat sensor might temporarily stop working. Sit fully on the seat.</li> </ul>

<b>Trouble</b> Water comes out of the wand when it should not.	
<b>Tests and results</b>	
When you stand up from the seat, the wand extends partly and sprays water for about 30 seconds before returning to its inactive position.	—
Is water coming out of the base of the wand?	<p>Sometimes water comes out of the base of the wand during washing. This is a necessary function.</p> <p>The water inside the warm water tank expands and comes out. This is normal.</p>
	<ul style="list-style-type: none"> <li>If water continues to come out when the NEOREST is not being used for washing, something is probably wrong. Close the water shut-off valve, and contact the installer or seller of this NEOREST.</li> </ul>

#### The deodorizer functions unexpectedly

<b>Trouble</b> The deodorizer functions when it should not.	
<b>Tests and results</b>	
The seat sensor could be falsely detecting a person and causing the deodorizer to function in the following circumstances, for example.	—
<ul style="list-style-type: none"> <li>When cleaning the unit</li> <li>When the flush panel is used</li> </ul>	

### The lid and seat open and close unexpectedly

Trouble The lid opens when it should not.		
Tests and results		Solutions
Does a "●" appear above "OPEN/CLOSE" on the back of the remote control?	<b>If "●" is lit</b> <ul style="list-style-type: none"> <li>When you change the remote control batteries, automatic opening and closing might be set to "on".</li> </ul>	<ul style="list-style-type: none"> <li>Make the appropriate setting again if you want to turn the automatic opening and closing function off. <ul style="list-style-type: none"> <li>▶ See page 39.</li> </ul> </li> </ul>
Trouble The lid closes when it should not.		
Tests and results		Solutions
Does a "●" appear above "OPEN/CLOSE" on the back of the remote control?	<b>If "●" is lit</b> <ul style="list-style-type: none"> <li>Automatic opening and closing is "on". If conditions make it difficult for body detection sensor A to detect a person, the lid might close even if a person is nearby.</li> </ul>	<ul style="list-style-type: none"> <li>If body detection sensor is covered by clothing, or if debris, water droplets or another substance blocks it, it might not detect the presence of a person. Check the body detection and seat sensors and remove anything blocking them. If clothing is blocking body detection sensor raise it so it no longer blocks the sensor. <ul style="list-style-type: none"> <li>▶ See pages 10, 11, 19 and 26.</li> </ul> </li> <li>Depending on clothing colour or material, the body detection sensor or seat sensor might not be able to detect the person. Sit on the seat fully and raise clothing so that the sensor can detect skin.</li> </ul>

### Toilet flushing occurs unexpectedly or stops suddenly

Trouble Toilet flushing occurs unexpectedly or automatic flushing occurs too soon.		
Tests and results		Solutions
Does a "●" appear above "FLUSH" on the back of the remote control?	<b>If "●" is lit</b> <ul style="list-style-type: none"> <li>If conditions make it difficult for the seat sensor to detect a person, the toilet might flush during use.</li> </ul>	<ul style="list-style-type: none"> <li>If you get up slightly from the seat, or sit forward on the seat, the seat sensor might temporarily stop working. Sit fully on the seat.</li> <li>If the seat sensor is covered by clothing, or if debris, water droplets or another substance blocks the sensor, it might not detect the presence of a person. Moreover, depending on clothing colour or material, the sensor might not be able to detect a person. Remove anything blocking the sensor. <ul style="list-style-type: none"> <li>▶ See pages 10 and 19.</li> </ul> </li> </ul>
	<b>If "●" is lit</b> <ul style="list-style-type: none"> <li>If you change the remote control batteries, "Automatic flushing" might be set to "on".</li> </ul>	<ul style="list-style-type: none"> <li>Make the appropriate setting again if you want to turn the automatic flushing function off. <ul style="list-style-type: none"> <li>▶ See page 42.</li> </ul> </li> </ul>
Is the mains plug inserted in the socket?	The toilet flushing starts automatically after inserting the mains plug in the socket.	—

### Other situations

Trouble Water is leaking from the plumbing connections.		
Tests and results		Solutions
Is a plumbing connection nut loose?		<ul style="list-style-type: none"> <li>Use a monkey wrench or similar tool to tighten the loose part more. <ul style="list-style-type: none"> <li>* If the water leak does not stop, close the water shut-off valve and request repair work. <ul style="list-style-type: none"> <li>▶ See page 49.</li> </ul> </li> </ul> </li> </ul>
Trouble The deodorizer sound becomes louder when you get up from the seat.		
Tests and results		Solutions
Is the Automatic Power Deodorizer on?	This louder sound is from the Automatic Power Deodorizer.	—

# Specifications

Rated power		220-240 V AC, 50 Hz	
Rated power consumption		400-470 W	
Standard power consumption per year *		214 (290) kWh/year	
Power cord length		About 1.0 m	
Toilet functions	Toilet flushing water volume	6 L (full flush), 3 L (light flush)	
	Water supply method	Hidden tank	
	Flushing method	Tornado cleaning (wash-down type)	
Other functions			
Washing equipment	Spray volume	Rear wash	About 0.45-0.8 L/min (at 0.2 MPa water pressure)
		Soft wash	About 0.5-0.85 L/min (at 0.2 MPa water pressure)
		Front wash	About 0.45-0.82 L/min (at 0.2 MPa water pressure)
	Spray temperature		Temperature adjustment range : about 30-40°C
	Heater capacity		308-367 W (hot water storage type)
Safety equipment		Temperature fuse, excessive heating prevention device (automatic recovery type bimetal), float switch to prevent heating when empty	
Warm air dryer	Warm air temperature		About 35-55°C
	Airflow		About 0.30 m <sup>3</sup> /min
	Heater capacity		251-299 W
	Safety equipment		Temperature fuse
Heated seat	Surface temperature		Temperature adjustment range: about 28-35°C (about 26°C with Smart Energy Saver)
	Heater capacity		47-56 W
	Safety equipment		Temperature fuse
Deodorizer equipment	Type		O <sub>2</sub> deodorizer
	Airflow		Standard mode: about 0.09 m <sup>3</sup> /min Power mode: about 0.16 m <sup>3</sup> /min
Water pressure		Minimum required water pressure: 0.1 MPa (when flowing) Maximum water pressure: 1.0 MPa (hydrostatic pressure)	
Water temperature		0-35°C	
Operating ambient temperature		0-40°C	
Dimensions	NEOREST SE	426 mm (width), 679 mm (depth), 484 mm (height)	
	NEOREST LE	426 mm (width), 676 mm (depth), 495 mm (height)	
Weight		About 45 kg (about 12 kg for the main unit and about 33 kg for the toilet)	

\* Standard power consumption per year without the energy saver functions is shown in the brackets.

# Warranty

## LIMITED TWO YEARS WARRANTY

- TOTO warrants its products to be free from manufacturing defects under normal use and service for a period of two (2) years from the date of purchase. This warranty is extended only to the ORIGINAL PURCHASER.
- TOTO's obligations under this warranty are limited to repair or replacement, at TOTO's option, of products or parts found to be defective, provided that such products were properly installed and used in accordance with this OWNER'S MANUAL. TOTO reserves the right to make such inspections as may be necessary to determine the cause of the defect. TOTO will not charge for labor or parts in connection with warranty repairs or replacements.  
**TOTO is not responsible for the cost of removal, return and/or reinstallation of products.**
- This warranty does not apply to the following items:
  - Damage or loss sustained in a natural calamity such as fire, earthquake, flood, thunder, electrical storm, etc.
  - Damage or loss resulting from any unreasonable use, misuse, abuse, negligence, or improper maintenance of the product.
  - Damage or loss resulting from removal, improper repair, or modification of the product.
  - Damage or loss resulting from sediments or foreign matter contained in a water system.
  - Damage or loss resulting from improper installation or from installation of a unit in a harsh and/or hazardous environment.
- This warranty gives you specific legal rights. You may have other rights which vary from country to country.
- To obtain warranty repair service under this warranty, you must take the product or deliver it prepaid to a TOTO service facility, together with a letter stating the problem, or contact a TOTO distributor or product service contractor, or directly to TOTO sales office. If, because of the size of the product or nature of the defect, the product can not be returned to TOTO, receipt by TOTO of written notice of the defect shall constitute delivery. In such case, TOTO may choose to repair the product at the purchaser's location or pay to transport the product to a service facility.

THIS WRITTEN WARRANTY IS THE ONLY WARRANTY MADE BY TOTO. REPAIR OR REPLACEMENT AS PROVIDED UNDER THIS WARRANTY SHALL BE THE EXCLUSIVE REMEDY AVAILABLE TO THE PURCHASER. TOTO SHALL NOT BE RESPONSIBLE FOR LOSS OF USE OF THE PRODUCT OR FOR OTHER INCIDENTAL, SPECIAL, OR CONSEQUENTIAL DAMAGE OR EXPENSES INCURRED BY PURCHASER, OR FOR LABOR OR OTHER COSTS DUE TO INSTALLATION OR REMOVAL, OR COSTS OF REPAIRS BY OTHERS, OR FOR ANY OTHER EXPENSE NOT SPECIFICALLY STATED ABOVE. EXCEPT TO THE EXTENT PROHIBITED BY APPLICABLE LAW, ANY IMPLIED WARRANTIES, INCLUDING THAT OF MERCHANTABILITY OR FITNESS FOR USE, ARE EXPRESSLY LIMITED TO THE DURATION OF THIS WARRANTY. SOME STATES DO NOT ALLOW LIMITATIONS ON HOW LONG AN IMPLIED WARRANTY LASTS, OR THE EXCLUSION OR LIMITATION OF INCIDENTAL OR CONSEQUENTIAL DAMAGE, SO THE ABOVE LIMITATION AND EXCLUSION MAY NOT APPLY TO YOU.



# Important User Guidance Information



If you want to dispose this product, do not mix it with general household waste. There is a separate collection system for used electronic products in accordance with legislation that requires proper treatment, recovery and recycling.

Private households in the EU, in Switzerland and Norway may return their used electronic products free of charge to designated collection facilities or to a retailer (if you purchase a similar new one).

For countries not mentioned above, please contact your local authorities for the correct method of disposal.

By doing so you will ensure that your disposed product undergoes the necessary treatment, recovery and recycling, which prevent potential negative effects on the environment and human health.

Only discard discharged batteries. They should not be disposed of with household waste, but rather at appropriate collection sites or at the product retailer.