



# PEDESTAL TOILET / TOILETTE MIT SOCKEL / TOILETTES AU SOL / WC/VASO/TAZZA DA TERRA

GB





Perform the installation work properly according to this Installation Guide so that the product can function well.  
After installation, fully explain how to use to your customer.



## Cautions and warnings (Always observe these warnings.)

Before installation, read these "Cautions and warnings" carefully and attach the equipment correctly. This manual uses various indications to guide safe installation of the product and to prevent injury to customers or other people and damage to property. This product should be installed by a professional. The indications and their meanings are as follows.

Symbol example	Meaning of symbol
 <b>CAUTION</b>	This indicates that misoperation could result in injury or physical damage.

The following symbols are used to classify and explain instructions that must be Followed.

	The  symbol indicates something that is prohibited.		The  symbol indicates something that must be done.
---	--	---	---

 <b>CAUTION</b>	
	<b>Always use the included parts or designated parts when installing the equipment.</b>
	<b>Do not strike ceramic parts or apply great force to them.</b> Doing so may damage ceramic parts, cause injury, or result in leaks that wet household goods or other items, causing property damage.
	<b>Do not forcibly bend the flexible water hose or damage it with burning cigarettes, cutters or other items.</b> If the flexible water hose is damaged, water might leak, wetting household goods or other items and causing property damage.

DE

Führen Sie die Installationsarbeiten entsprechend dieses Installationshandbuchs durch, um sicherzustellen, dass das Produkt richtig funktioniert. Geben Sie dem Kunden nach der Installation genaue Anweisungen zur Benutzung.





## Vorsichtsmaßnahmen und Warnungen

(Beachten Sie diese Warnungen immer.)

Bitte lesen Sie diese "Vorsichtsmaßnahmen und Warnungen" vor der Installation aufmerksam durch und bringen Sie das Produkt entsprechend an. Diese Anleitung enthält zahlreiche Hinweise zur sicheren Installation des Produkts sowie Anmerkungen, wie Sie Verletzungen und Schäden vermeiden können. Das Produkt sollte durch einen professionellen Installateur eingebaut werden. Die Hinweise und ihre Bedeutung sind im Folgenden erklärt.

Symbol-Beispiel	Bedeutung des Symbols
 <b>VORSICHT</b>	Dies weist darauf hin, dass ein falscher Betrieb zu Verletzungen oder körperlichen Schädigungen führen kann.

Die folgenden Symbole werden verwendet, um Anweisungen zu klassifizieren und zu erläutern, die befolgt werden müssen.

	Das Symbol  gibt an, dass etwas verboten ist.		Das Symbol  gibt etwas an, das getan werden muss.
---	--	---	--

 <b>VORSICHT</b>	
	<b>Verwenden Sie bei der Installation ausschließlich die im Lieferumfang enthaltenen oder für das Gerät bestimmten Teile.</b>
	<b>Lassen Sie keine Gegenstände auf die Keramikteile fallen und üben Sie keine übermäßige Kraft auf sie aus.</b> Hierdurch können Keramikteile beschädigt werden und es kann zu Verletzungen oder undichten Stellen kommen, wodurch Haushaltsgegenstände o.ä. in Kontakt mit Wasser geraten oder Wasserschäden anderer Art entstehen können.
	<b>Biegen Sie den Wasserzulaufschlauch nicht übermäßig und beschädigen Sie ihn nicht beispielsweise mit brennenden Zigaretten oder Schneidwerkzeugen.</b> Dadurch könnte der Wasserzulaufschlauch beschädigt werden und es könnten undichte Stellen entstehen, wodurch Ihre Haushaltsgegenstände nass werden könnten oder Ihr Hausrat könnte in anderer Weise beschädigt werden.

FR

Exécutez correctement l'installation en suivant ce Guide d'installation afin que le produit fonctionne convenablement. Une fois l'installation terminée, expliquez bien au client comment il doit utiliser le produit.





## Mises en garde et avertissements

(Respectez toujours ces avertissements.)

Avant l'installation, lisez attentivement ces "Mises en garde et avertissements" et fixez convenablement l'appareil. Ce manuel utilise diverses indications pour faciliter l'installation sûre du produit et éviter toute blessure aux clients ou à d'autres personnes et tous dommages à vos biens. Ce produit devrait être installé par un expert. Les indications et leurs significations sont les suivantes.

Exemple de symbole	Signification du symbole
 <b>MISE EN GARDE</b>	Cela indique que toute utilisation incorrecte pourrait entraîner une blessure ou un dommage physique.

Les symboles suivants sont utilisés pour classifier et expliquer les instructions devant être suivies.

	Le symbole  indique que quelque chose est interdit.		Le symbole  indique que quelque chose doit être fait.
---	--	---	--

 <b>MISE EN GARDE</b>	
	<b>Utilisez toujours les pièces fournies ou les pièces recommandées lorsque vous installez l'appareil.</b>
	<b>Ne frappez pas sur les pièces en céramique et ne les soumettez pas à une force importante.</b> Cela pourrait endommager les pièces en céramique, entraîner des blessures ou provoquer des fuites pouvant mouiller vos objets domestiques ou autres et endommager vos biens.
	<b>Ne pliez pas exagérément le flexible d'alimentation en eau et ne l'abîmez pas avec une cigarette incandescente ou un cutter, par exemple.</b> Cela risquerait d'endommager le flexible d'alimentation en eau, entraînant une fuite d'eau pouvant mouiller vos objets et endommager vos biens.

IT

Eseguire l'installazione in modo appropriato, attenendosi alle istruzioni riportate nel presente Manuale di installazione, in modo che il prodotto possa funzionare correttamente. In seguito all'installazione, spiegare al cliente come utilizzare il prodotto.





## Avvisi di Pericolo e Attenzione



(Si raccomanda di attenersi scrupolosamente a quanto indicato in questi avvisi.)

Prima di procedere all'installazione, leggere attentamente i presenti "Avvisi di Pericolo e Attenzione" e collegare l'apparecchio in modo corretto. Questo manuale contiene varie indicazioni importanti per un'installazione corretta e sicura del prodotto, e per evitare infortuni agli utenti e ad altre persone e danni alle cose o agli edifici. Questo prodotto deve essere installato da una persona autorizzata. Gli avvisi, segnalati da apposite icone, hanno il seguente significato.







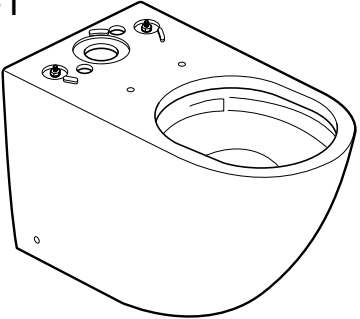
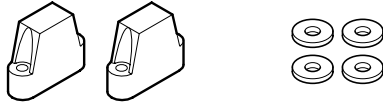
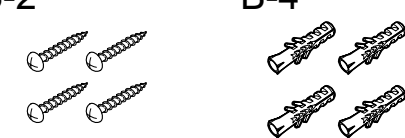
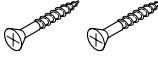

Esempio di simbolo	Significato del simbolo
 <b>ATTENZIONE</b>	Questo simbolo indica che in caso di operazioni scorrette si potrebbero verificare infortuni o danni fisici.

In questo manuale vengono utilizzati i simboli riportati di seguito per classificare le tipologie di istruzioni contenute nei paragrafi successivi.

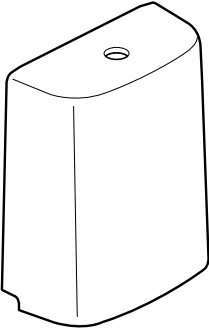
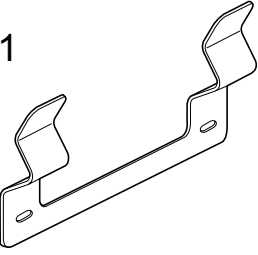
	Il simbolo  indica operazioni vietate.		Il simbolo  indica operazioni che devono essere eseguite obbligatoriamente.
---	---	---	--

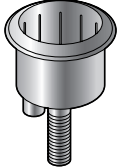
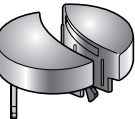
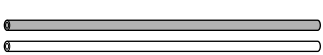
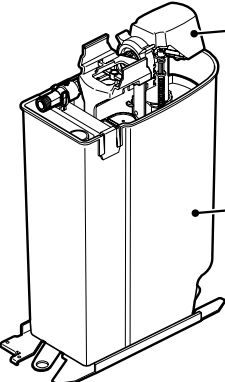
 <b>ATTENZIONE</b>	
	<b>Durante l'installazione del prodotto, utilizzare sempre i componenti forniti in dotazione o specificate.</b>
	<b>Fare attenzione a non urtare le parti in ceramica e a non esercitare forze eccessive su di esse.</b> In caso contrario, le parti in ceramica potrebbero venire danneggiate e si potrebbero provocare infortuni o fuoriuscite d'acqua, con il rischio di bagnare gli oggetti della casa o altri oggetti e di provocare danni all'edificio.
	<b>Non piegare eccessivamente il tubo flessibile di ingresso acqua e fare attenzione a non danneggiarlo con sigarette accese, taglierini o simili.</b> In caso di mancata osservanza di questa istruzione, il tubo flessibile di ingresso acqua potrebbe venire danneggiato, provocando fuoriuscite d'acqua, con il rischio di bagnare gli oggetti della casa e di provocare danni all'edificio dovuti alle infiltrazioni.

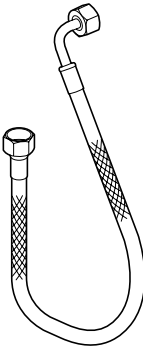
**Included Parts / Im Lieferumfang enthaltene Teile / Pièces fournies / Parti in dotazione**

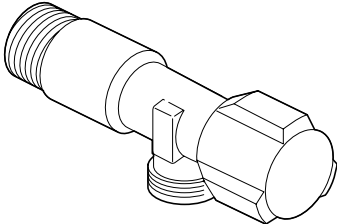
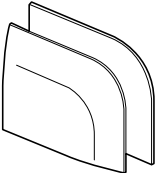
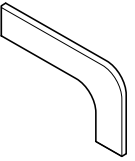
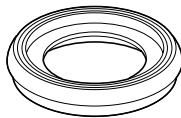
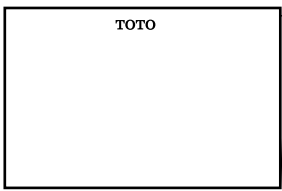
<p>A-1</p> 	<p>B-1 B-3</p>  <p>B-2 B-4</p> 	<p>C-1</p>  <p>C-2</p> 	<p>D-1</p> 
<p>E-1</p>  <p>E-2 E-3</p> 	<p>F-1</p>  <p>F-2</p>  <p>F-3</p> 	<p>G-2</p>  <p>G-3</p>  <p>G-4</p> 	<p>H-1</p>  <p>H-2</p> 
<p>I-1</p> 	<p>J-1</p>  <p>J-2</p> 	<p>K-1</p> 	<p>L-1</p> 

**Set-up Drawing / Aufbauzeichnung  
Schéma d'installation / Schema di installazione**

**Parts / Teile / Pièces / Componenti/parti**

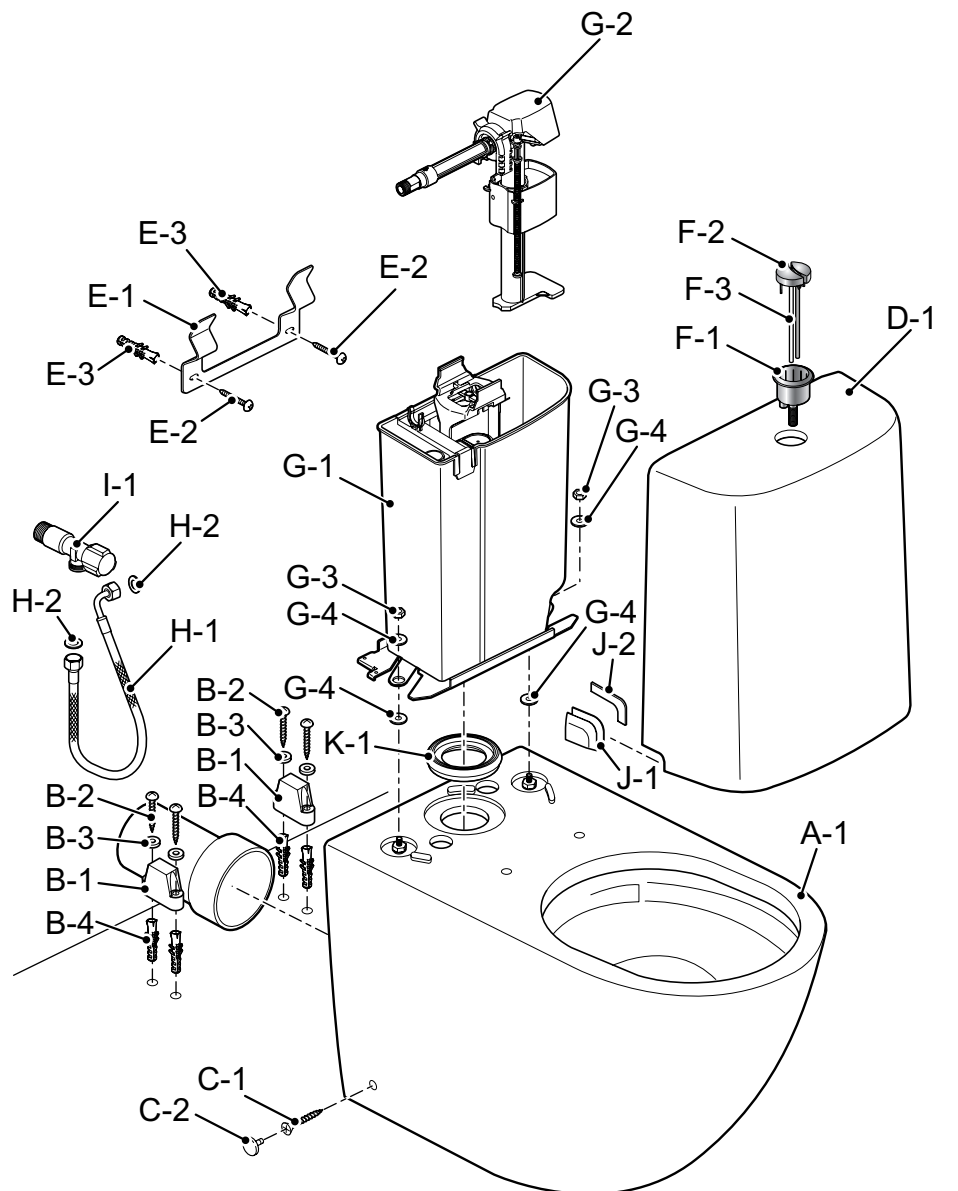
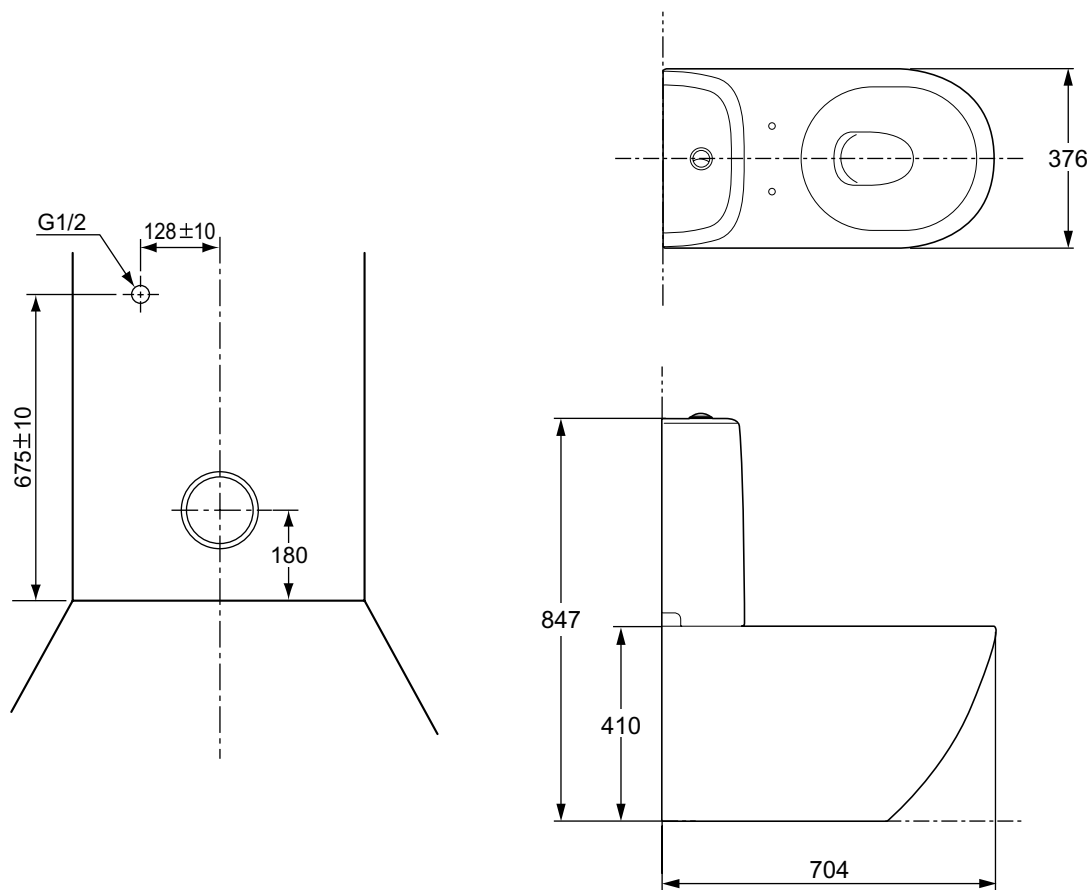

(mm)

# Installation Procedures / Vorgehensweise für die Installation Procédures d'installation / Procedure di installazione

