

TOTO

GIOVANNONI

SERIES

Washlet

TCF892G/GE

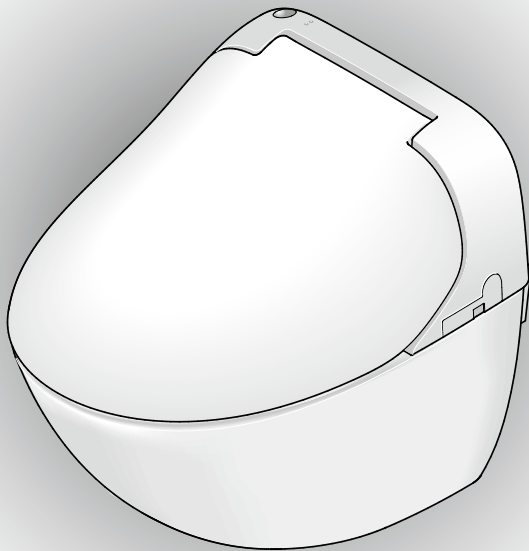

Installation Guide
Installationsanleitung
Guide d'installation
Manuale di installazione

WASHLET®

Cautions and warnings	2
Before Installing the Washlet	3
Vorsichtsmaßnahmen und Warnungen	4
Vor der Installation des Washlets	5
Mises en garde et avertissements	6
Avant d'installer le Washlet	7
Avvisi di pericolo e attenzione	8
Prima di installare il Washlet	9
Included parts / Mitgelieferte Teile / Pièces fournies / Parti in dotazione	10
Required tools / Erforderliches Werkzeug / Outils requis / Utensili richiesti	10
Parts / Teile / Pièces / Parti	11
Meaning of the indications / Bedeutung der Hinweise / Signification des indications / Significato delle indicazioni	12
Installing the Washlet / Installation des Washlets / Installation du Washlet / Installazione del Washlet	12
Testing the operation of the Washlet / Funktionstest des Washlets / Test du fonctionnement du Washlet / Prova di funzionamento del Washlet	18



To installation contractors:	Für Installateure:
Please explain to the customer the functions of the Washlet and how to use them. In new buildings or other places where there will be a significant time until the customer receives the product, please disconnect the mains plug.	Erklären Sie dem Kunden bitte die Funktions- und Bedienungsweise des Washlets. In neuen Gebäuden oder an Orten, wo es geraume Zeit dauert, bis der Kunde das Gerät zum ersten Mal benutzt, ziehen Sie bitte den Netzstecker.
Aux prestataires d'installation:	Per gli installatori:
Veuillez expliquer au client les fonctions du Washlet et comment les utiliser. Dans de nouveaux bâtiments où d'autres lieux où une durée importante s'écoulera avant que le client ne reçoive le produit, veuillez déconnecter la prise secteur.	Si prega di illustrare ai clienti le funzioni del Washlet e le loro modalità di utilizzo. Negli edifici nuovi e in altri luoghi in cui dovrà passare molto tempo prima che il cliente inizi a utilizzare il prodotto, staccare la spina di alimentazione.

- "Washlet" is a registered trademark of TOTO.
- "Washlet" ist ein eingetragenes Warenzeichen von TOTO.
- "Washlet" est une marquée déposée de TOTO.
- "Washlet" è un marchio registrato di TOTO.

Cautions and warnings

Before installing your Washlet, be sure to read the following installation instructions. Install the product only as described in this guide.

Follow all safety precautions and warnings.



 WARNING	<p>When this appears next to a topic, this indicates that misoperation could result in death or serious injury.</p>	 CAUTION	<p>When this appears next to a topic, this indicates that misoperation may result in injury or physical damage.</p>
---	--	---	--

Symbol example

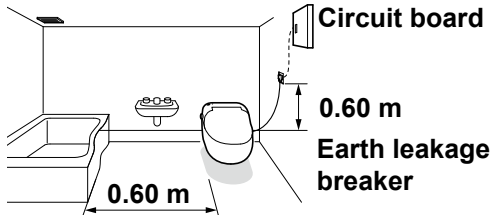

	<p>The  symbol indicates something that is prohibited.</p>		<p>The  symbol indicates something that must be done.</p>
---	---	---	--

- This equipment is Class 1, so it is necessary to attach it to an earthed connection.
- Install this equipment close to a mains socket.
- Use the new hose set included with this equipment. Do not reuse an old hose set.

WARNING

 Required	<ul style="list-style-type: none"> • Since this is electronic equipment, do not locate it in a place where it might be splashed or otherwise become wet. Likewise, do not locate it in a humid place where water could drip onto the surface of the Washlet. When using it in a bathroom, install a ventilation fan or ventilation opening, so that the bathroom has sufficient airflow. Install the Washlet at least 0.6 m away from any bathtub. (Failure to observe this caution may result in fire or electrical shock.) • Prepare the socket for the electrical wiring as follows. (Failure to observe this caution may result in fire or electrical shock.) <ol style="list-style-type: none"> a. Provide electric current to the socket (device) using a differential residual electric current device (DDR) with a released current that does not exceed 30 mA. b. Locate the socket (device) and its wiring plug at least 0.6 m from the outside edge of a shower chamber or bathtub. * Confirm that the wiring for items a and b above has been completed. If the wiring has not been completed, request completion from the business that installed the unit. • Be sure to install an earth wire in a place where connection is ensured. (If the earth wire is not installed, electric shocks could occur if there is a malfunction or a short circuit.) Note: Use copper wire with a diameter of 1.6 mm or more and with an earth resistance of 100 Ω or less. * If the earth wire has not been installed, request installation from the business that installed the unit. • Always insert the electrical cord completely into the socket (220-240 V AC, 50 Hz). (Failure to observe this caution may result in fire or electrical shock.) • Make the connection so that the electrical plug is easy to reach. • Always connect the Washlet to the cold water supply. (Failure to do so could cause burns or malfunction of the equipment.) • Follow the installation requirements for the country in which the Washlet is being installed. 	<p style="text-align: center;">Ventilation fan or ventilation opening</p> 
 Prohibited	<ul style="list-style-type: none"> • Use only tap water or potable well water (groundwater). (Use of other water could cause skin inflammation or other problems.) • Do not use this product with any power supply other than specified (220-240 V AC, 50 Hz). (Failure to observe this caution may result in fire or electrical shock.) 	

! CAUTION

 Required	<ul style="list-style-type: none"> After cleaning the water filter, thoroughly tighten the drain valve with built-in water filter. (Failure to do so could cause a water leak.)
	<ul style="list-style-type: none"> Follow the Installation Guide thoroughly during installation. (Failure to attach things correctly could cause water leaks.)
 Prohibited	<ul style="list-style-type: none"> Do not detach the drain valve with built-in water filter while the water shut-off valve is still open. (Doing so will cause water to spill.)
	<ul style="list-style-type: none"> Do not bend or crush the water supply hose. (This could cause a water leak.)
	<ul style="list-style-type: none"> Do not lift the Washlet by the seat or toilet lid. (Injury could result if the main Washlet unit becomes dislodged and falls.)

Before Installing the Washlet

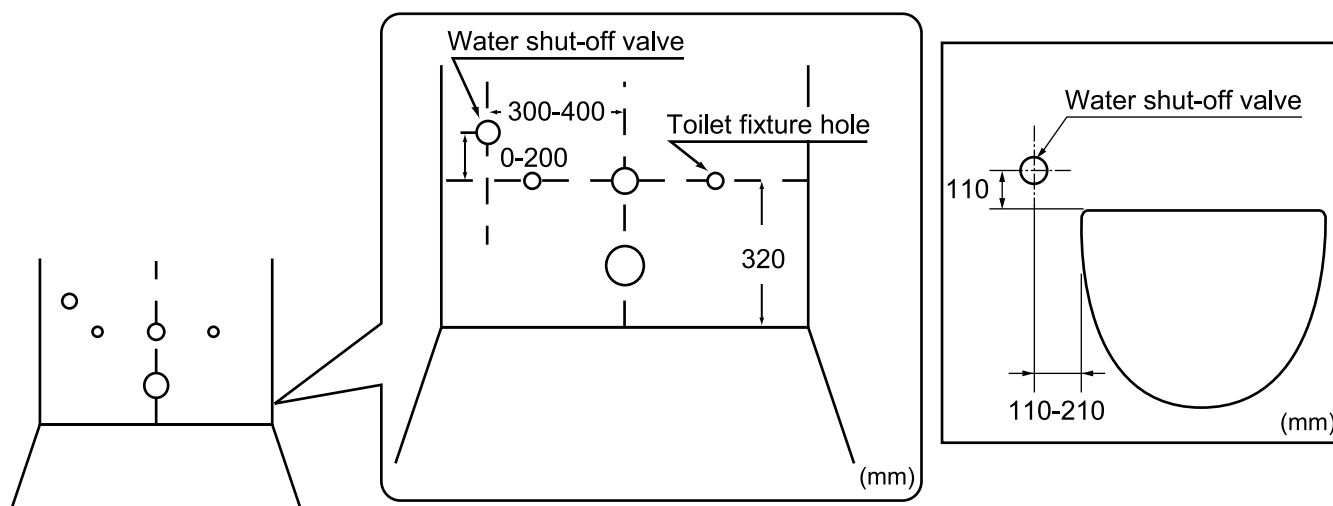

- Do not transmit electrical current or supply water to the unit until the installation process is complete.
- Do not damage the connected parts at the end of the water supply hose.
- The power voltage is 220-240 V AC (50 Hz). The rated energy consumption is 274-319 W. Use wiring and electrical sockets that are appropriate for this level of power. (Independent wiring is recommended.)
- Do not install the base plate to the Washlet when it is not attached to the toilet. (Turning the Washlet on in this condition could result in product damage.)
- The power cord is about 0.9 m long. Confirm that a mains socket is installed within reach to allow easy installation and removal of the Washlet.
- Use a water supply with pressure between 0.1 - 1.0 Mpa.
- The water temperature range should be between 0 - 35°C.
- The length of the connection hose is 0.5 m. The water supply should be located to allow easy installation and removal of the Washlet.
- Before installing the Washlet, confirm that the water supply is on a regulated position.



Vorsichtsmaßnahmen und Warnungen

Lesen Sie vor der Installation des Washlets unbedingt die folgenden Installationsanweisungen. Installieren Sie das Washlet auf keinen Fall auf andere Weise als in dieser Anleitung beschrieben.

Beachten Sie bitte alle Vorsichtsmaßnahmen und Warnungen.



 WARNUNG	<p>Wenn ein Abschnitt mit diesem Symbol gekennzeichnet ist, wird darauf hingewiesen, dass bei fehlerhafter Handhabung die Gefahr von schweren oder gar tödlichen Verletzungen besteht.</p>	 VORSICHT	<p>Wenn ein Abschnitt mit diesem Symbol gekennzeichnet ist, wird darauf hingewiesen, dass bei fehlerhafter Handhabung möglicherweise Verletzungsgefahr oder die Gefahr von Sachschäden besteht.</p>
---	--	--	---

Beispielsymbole

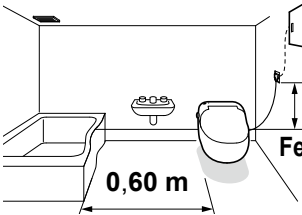

	Das Symbol  gibt an, dass etwas verboten ist.		Das Symbol  weist auf etwas hin, das getan werden muss.
---	--	---	--

- Bei diesem Gerät handelt es sich um ein Gerät der Klasse 1, es muss daher an eine Steckdose mit Schutzerde angeschlossen werden.
- Installieren Sie das Gerät in der Nähe einer Netzsteckdose.
- Verwenden Sie die neuen, mit diesem Gerät gelieferten Schläuche. Verwenden Sie keine alten Schläuche.

WARNUNG

 Erforderlich	<ul style="list-style-type: none"> • Da es sich hierbei um ein Elektrogerät handelt, dürfen Sie es nicht an einem Ort aufstellen, an dem es durch Spritzwasser oder auf andere Weise nass werden könnte. Stellen Sie es auch nicht an einem feuchten Ort auf, an dem Wasser auf die Oberseite des Washlets tropfen könnte. Bei Verwendung in einem Badezimmer muss mit einem Lüfter oder einer Lüftungsöffnung für ausreichende Luftzirkulation gesorgt werden. Installieren Sie das Washlet mindestens 0,6 m von Badewannen u. Ä. entfernt. (Ansonsten besteht die Gefahr, dass ein Feuer entsteht oder Sie einen elektrischen Schock bekommen.) • Beachten Sie beim Elektroanschluss unbedingt folgende Hinweise. (Ansonsten besteht die Gefahr, dass ein Feuer entsteht oder Sie einen elektrischen Schock bekommen.) <ol style="list-style-type: none"> a. Die Steckdose (das Gerats) fur die Stromversorgung muss mit einer Fehlerstromschutzschaltung (RCD) mit einem Auslosestrom von maximal 30 mA gesichert sein. b. Die Steckdose (das Gerat) und der Stecker mussen sich mindestens 0,6 m von der Auenkannte einer Duschkabine oder Badewanne entfernt befinden. * Vergewissern Sie sich, dass die Verkabelung wie unter a. und b. beschrieben vorgenommen wurde. Wenn die Verkabelung nicht entsprechend vorgenommen wurde, wenden Sie sie diesbezuglich an das Geschaft, in dem Sie das Gerat gekauft haben. • Es muss ein Schutzleiter verlegt sein, und zwar so, dass die Verbindung gewahrleistet ist. (Wenn kein Schutzleiter verlegt ist, kann es bei einer Fehlfunktion oder einem Kurzschluss zu einem elektrischen Schlag kommen.) Hinweis: Verwenden Sie Kupferdraht mit einem Durchmesser von mindestens 1,6 mm und mit einem Erdungswiderstand von maximal 100 Ω. * Wenn kein Schutzleiter verlegt ist, wenden Sie sie diesbezuglich an das Geschaft, in dem Sie das Gerat gekauft haben. • Stecken Sie den Netzstecker immer ganz in die Steckdose (220-240 V Wechselstrom, 50 Hz). (Ansonsten besteht die Gefahr, dass ein Feuer entsteht oder Sie einen elektrischen Schock bekommen.) • Achten Sie darauf, dass der Netzstecker leicht zuganglich ist. • Schlieen Sie das Washlet immer an die Kaltwasserversorgung an. (Bei Nichtbeachtung kann es zu Verbrennungen und Fehlfunktionen des Gerats kommen.) • Befolgen Sie bitte die Installationsanweisungen fur das Land, in dem das Washlet installiert wird. 	<p>Lufter oder Luftungsoffnung</p>  <p>Schaltkasten</p> <p>0,60 m</p> <p>Fehlerstromschutzschalter</p> <p>0,60 m</p>
 Verboten	<ul style="list-style-type: none"> • Verwenden Sie ausschließlich Leitungswasser oder als Leitungswasser geeignetes Brunnenwasser (Grundwasser). (Bei Verwendung anderer Wasserquellen kann es zu Hautreizungen und anderen Problemen kommen.) • Benutzen Sie fur dieses Produkt keine andere als die angegebene Stromversorgung (220-240 V Wechselstrom, 50 Hz). (Ansonsten besteht die Gefahr, dass ein Feuer entsteht oder Sie einen elektrischen Schock bekommen.) 	

⚠ VORSICHT

 Erforderlich	<ul style="list-style-type: none"> Nach dem Reinigen des Wasserfilters müssen Sie das Ablaufventil mit eingebautem Wasserfilter fest schließen. (Bei Nichtbeachtung kann Wasser austreten.)
	<ul style="list-style-type: none"> Befolgen Sie bei der Installation die Anweisungen in der Installationsanleitung genau. (Bei fehlerhaften Verbindungen kann Wasser austreten.)
 Verboten	<ul style="list-style-type: none"> Nehmen Sie das Ablaufventil mit eingebautem Wasserfilter nicht ab, solange das Wasserabsperrventil geöffnet ist. (Andernfalls strömt Wasser aus.)
	<ul style="list-style-type: none"> Biegen und quetschen Sie den Wasserzulaufschlauch nicht. (Andernfalls kann Wasser austreten.)
	<ul style="list-style-type: none"> Heben Sie das Washlet nicht am Sitz oder am Toilettendeckel an. (Wenn sich das Washlet-Hauptgerät löst und herunterfällt, besteht Verletzungsgefahr.)

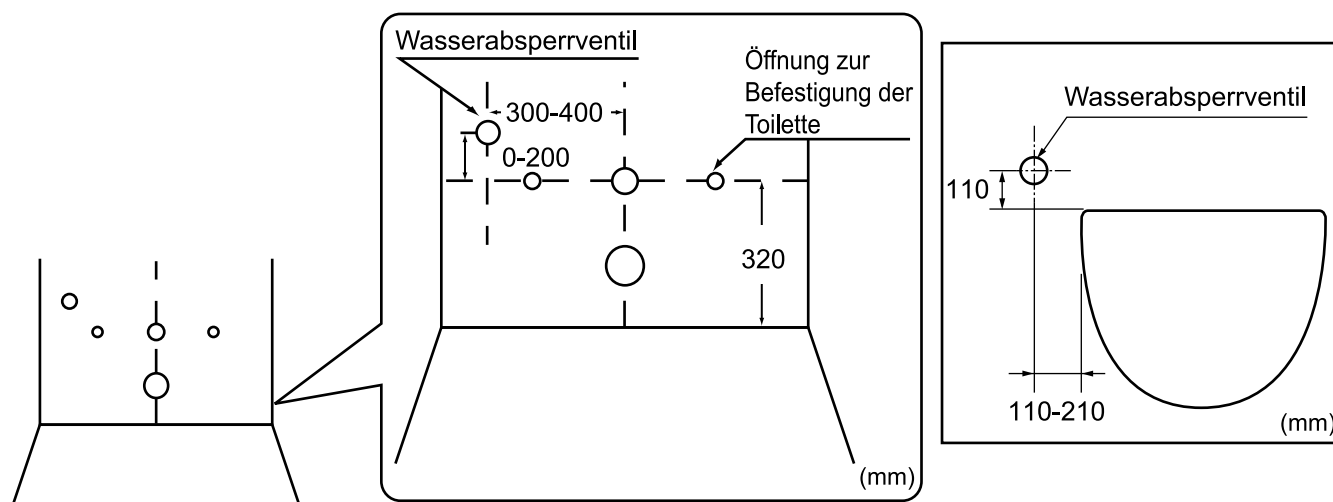

Vor der Installation des Washlets

- Schließen Sie die Installation vollständig ab, bevor Sie das Gerät mit Strom oder Wasser versorgen.
- Beschädigen Sie die an das Ende des Wasserzulaufschlauchs angeschlossenen Teile nicht.
- Die Betriebsspannung beträgt 220-240 V Wechselstrom (50 Hz). Die Nennleistungsaufnahme beträgt 274-319 W. Achten Sie darauf, dass die Verkabelung und die Steckdose auf diese Anschlusswerte ausgelegt sind. (Es empfiehlt sich, das Gerät an einen eigenen Stromkreis anzuschließen.)
- Installieren Sie die Auflageplatte nicht am Washlet, wenn dieses nicht an der Toilette angebracht ist. (Andernfalls kann es zu Beschädigungen am Gerät kommen, wenn Sie das Washlet einschalten.)
- Das Netzkabel ist ungefähr 0,9 m lang. Vergewissern Sie sich, dass in der Nähe eine leicht zugängliche Netzsteckdose installiert ist, so dass sich das Washlet leicht anschließen und trennen lässt.
- Der Wasserversorgungsdruck muss zwischen 0,1 und 1,0 MPa liegen.
- Die Wassertemperatur muss zwischen 0 und 35°C liegen.
- Der Verbindungsschlauch ist 0,5 m lang. Achten Sie darauf, dass sich in der Nähe eine Wasserentnahmestelle befindet, so dass sich das Washlet leicht anschließen und trennen lässt.
- Vergewissern Sie sich vor der Installation des Washlets, dass der Wasseranschluss sich an einer geeigneten Stelle befindet.



Mises en garde et avertissements

Avant d'installer votre Washlet, assurez-vous de lire les instructions d'installation suivantes. Installez ce produit en suivant exclusivement la procédure décrite dans ce guide. Suivez toutes les précautions et les avertissements de sécurité.



 AVERTISSEMENT	<p>Lorsque ce symbole apparaît en regard d'une rubrique, cela indique que toute utilisation incorrecte pourrait entraîner la mort ou une blessure grave.</p>	 MISE EN GARDE	<p>Lorsque ce symbole apparaît en regard d'une rubrique, cela indique que toute utilisation incorrecte peut entraîner une blessure ou un dommage physique.</p>
---	--	---	--

Exemple de symbole

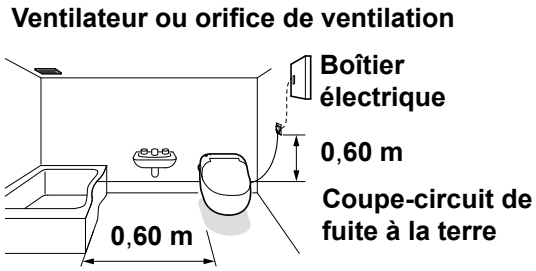

	<p>Le symbole  indique que quelque chose est interdit.</p>		<p>Le symbole  indique que quelque chose doit être fait.</p>
---	---	---	---

- Ce matériel est de catégorie 1, c'est pourquoi il est nécessaire de le connecter à la terre.
- Installez ce matériel près d'une prise secteur.
- Utilisez le nouveau jeu de flexibles inclus avec cet appareil. Ne réutilisez pas un ancien jeu de flexibles.

AVERTISSEMENT

 Requis	<ul style="list-style-type: none"> • Dans la mesure où il s'agit d'un matériel électronique, ne le placez pas à un emplacement où il pourrait être éclaboussé ou soumis à l'humidité. De même, ne le placez pas dans un lieu humide où de l'eau pourrait couler sur la surface du Washlet. Lorsque vous l'utilisez dans une salle de bain, installez un ventilateur ou un orifice de ventilation afin que la salle de bain soit suffisamment ventilée. Installez le Washlet à au moins 0,6 m d'une baignoire. (Le non-respect de cette mise en garde pourrait entraîner un incendie ou l'électrocution.) • Préparez la prise pour le câblage électrique en procédant comme suit. (Le non-respect de cette mise en garde pourrait entraîner un incendie ou l'électrocution.) <ol style="list-style-type: none"> a. Alimentez la prise en courant électrique (appareil) à l'aide d'un appareil électrique différentiel à double vitesse de transfert émettant une puissance ne dépassant pas 30 mA. b. Placez la prise femelle (appareil) à 0,6 m minimum du bord extérieur d'une douche ou d'une baignoire. <p>* Vérifiez que le câblage des éléments a et b ci-dessus a été réalisé. Si le câblage n'est pas réalisé, demandez à l'entreprise ayant installé l'appareil de le faire.</p> • Assurez-vous d'installer un conducteur de terre dans un lieu où ce type de branchement est possible. (Si le conducteur de terre n'est pas installé, des chocs électriques pourraient survenir en cas de dysfonctionnement ou de court-circuit.) Remarque: Utilisez un fil de cuivre d'un diamètre de 1,6 mm ou plus et d'une résistance à la terre de 100 Ω ou inférieure. * Si le conducteur de terre n'a pas été installé, demandez à l'entreprise ayant installé l'appareil de le faire. • Insérez toujours le câble électrique complètement dans la prise (220-240 V CA, 50 Hz). (Le non-respect de cette mise en garde pourrait entraîner un incendie ou l'électrocution.) • Faites le branchement de façon à ce que la prise électrique soit facile à atteindre. • Connectez toujours le Washlet à l'alimentation en eau froide. (Le non-respect de cette instruction pourrait entraîner des brûlures ou un dysfonctionnement de l'appareil.) • Suivez les exigences d'installation pour le pays dans lequel le Washlet est installé. 	
 Interdit	<ul style="list-style-type: none"> • N'utilisez que de l'eau du robinet ou de l'eau d'un puits potable (provenant de nappes). (L'utilisation d'autres types d'eau pourrait entraîner une inflammation de la peau ou d'autres problèmes.) • N'utilisez pas ce produit avec une alimentation électrique autre que celle spécifiée (220-240 V CA, 50 Hz). (Le non-respect de cette mise en garde pourrait entraîner un incendie ou l'électrocution.) 	

⚠ MISE EN GARDE

 Requis	<ul style="list-style-type: none"> Après avoir nettoyé le filtre à eau, serrez fermement le robinet de vidange avec filtre à eau intégré. (Le non-respect de cette mise en garde pourrait entraîner une fuite.) Suivez le guide d'installation avec attention pendant l'installation. (Un branchement incorrect pourrait entraîner des fuites d'eau.)
 Interdit	<ul style="list-style-type: none"> Ne détachez pas le robinet de vidange avec filtre à eau intégré lorsque le robinet de sectionnement est encore ouvert. (De l'eau pourrait se déverser.) Ne pliez pas ou n'écrasez pas le flexible d'alimentation en eau. (Cela pourrait entraîner une fuite d'eau.) Ne soulevez pas le Washlet par le siège ou l'abattant. (Une blessure pourrait survenir si l'unité Washlet principale se déloge et tombe.)

Avant d'installer le Washlet

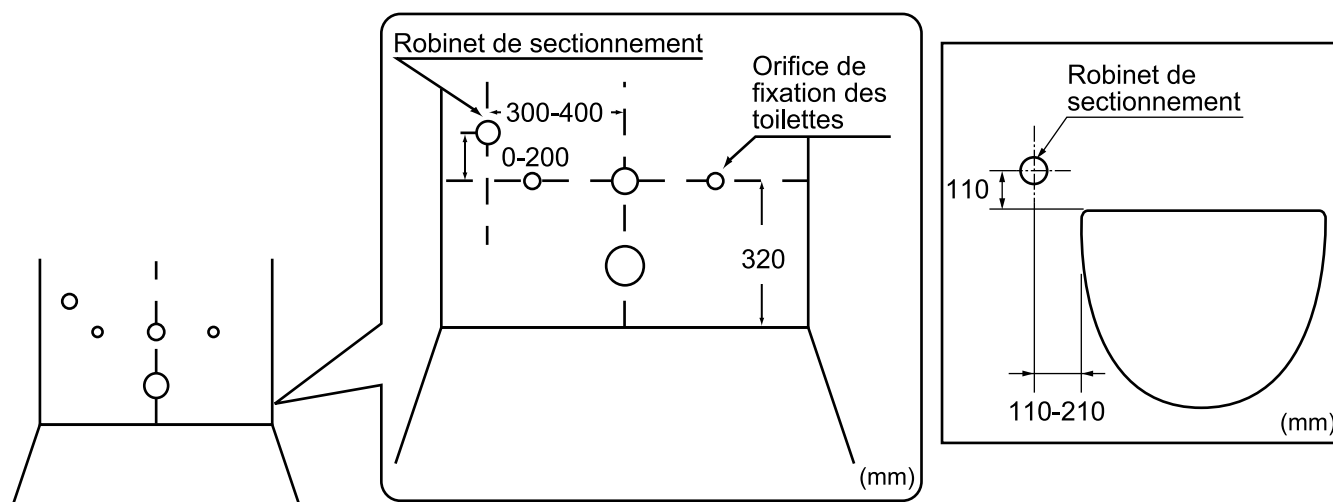

- Ne transmettez pas de courant électrique et n'alimentez pas l'unité en eau avant que la procédure d'installation ne soit terminée.
- N'endommagez pas les pièces connectées à l'extrémité du flexible d'alimentation en eau.
- La tension d'alimentation est de 220-240 V CA (50 Hz). La consommation d'énergie nominale est de 274-319 W. Utilisez des câbles et des prises électriques adaptés à ce niveau d'alimentation. (Un câblage indépendant est recommandé.)
- Ne fixez pas le socle au Washlet lorsque celui-ci n'est pas fixé aux toilettes. (Si le Washlet est allumé dans ces conditions, le produit pourrait être endommagé.)
- Le cordon d'alimentation mesure environ 0,9 m de long. Vérifiez qu'une prise secteur est installée à portée afin de faciliter l'installation et le retrait du Washlet.
- Utilisez une alimentation en eau d'une pression située entre 0,1 et 1,0 Mpa.
- La plage de température de l'eau doit être située entre 0 et 35°C.
- La longueur du flexible de branchement est de 0,5 m. L'alimentation en eau doit être située de façon à permettre une installation et un retrait faciles du Washlet.
- Avant d'installer le Washlet, vérifiez que l'alimentation en eau est en position stabilisée.





Avvisi di pericolo e attenzione

Prima di installare il Washlet, leggere le seguenti istruzioni di installazione. Per l'installazione, adottare esclusivamente le procedure riportate nel presente manuale.

Rispettare tutte le istruzioni di sicurezza e le indicazioni riportate negli avvisi.



 PERICOLO	<p>I paragrafi preceduti da questa indicazione contengono descrizioni importanti. In caso di inosservanza, si possono verificare gravi infortuni, anche mortali.</p>	 ATTENZIONE	<p>I paragrafi preceduti da questa indicazione contengono descrizioni importanti. In caso di inosservanza, si possono verificare infortuni o danni alle cose.</p>
--	--	--	---

Esempio di simbolo

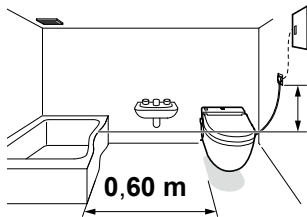

	Il simbolo  indica operazioni vietate.		Il simbolo  indica operazioni che devono essere eseguite obbligatoriamente.
---	---	---	--

- Questa apparecchiatura è di Classe 1, pertanto è necessario effettuare il collegamento a un sistema di messa a terra.
- L'apparecchiatura deve essere installata in prossimità di una presa di alimentazione.
- Utilizzare il set di tubi nuovi fornito insieme all'apparecchiatura. Non riutilizzare tubi flessibili utilizzati in precedenza.

PERICOLO

 Obbligatorio	<ul style="list-style-type: none"> • Il Washlet è un apparecchio elettronico, pertanto non deve essere installato in luoghi in cui potrebbe essere spruzzato o bagnato. Analogamente, non deve essere installato in luoghi umidi o in cui l'acqua potrebbe gocciolare sulle sue superfici. Se viene installato in una stanza da bagno, prevedere un impianto di ventilazione o un'apertura per la ventilazione, in modo da garantire un'adeguata circolazione dell'aria. Il Washlet deve essere installato ad almeno 0,6 m di distanza dalle vasche da bagno. (In caso di mancata osservanza di questa indicazione si potrebbero verificare incendi o scosse elettriche.) • Preparare la presa per il collegamento elettrico attenendosi alle istruzioni sotto riportate. (In caso di mancata osservanza di questa indicazione si potrebbero verificare incendi o scosse elettriche.) <ol style="list-style-type: none"> a. La presa elettrica deve essere alimentata tramite collegamento a un impianto munito di Dispositivo a corrente Differenziale Residua (DDR) con corrente nominale non superiore a 30 mA. b. La presa e la spina di collegamento devono essere poste ad almeno 0,6 m di distanza dal bordo esterno di una cabina doccia o vasca da bagno. <p>* Verificare che i collegamenti descritti ai punti a e b siano stati completati. Qualora i collegamenti non siano stati completati, richiedere l'intervento dell'installatore dell'unità.</p> • Si raccomanda di installare il filo di terra in un punto in cui il collegamento possa essere eseguito correttamente. (Se il filo di terra non è installato, in caso di anomalie di funzionamento o cortocircuiti si potrebbero verificare scosse elettriche.) Nota: Utilizzare un filo di rame da almeno 1,6 mm di diametro con una resistenza di terra massima di 100 Ω. * Se il filo di terra non è stato installato, richiedere l'intervento dell'installatore dell'unità. • Il cavo elettrico deve essere sempre inserito a fondo nella presa (220-240 V CA, 50 Hz). (In caso di mancata osservanza di questa indicazione si potrebbero verificare incendi o scosse elettriche.) • Effettuare il collegamento in modo che la spina elettrica sia facilmente raggiungibile. • Il Washlet deve essere sempre collegato all'ingresso dell'acqua fredda. (In caso contrario, si potrebbero verificare ustioni o anomalie di funzionamento dell'apparecchiatura.) • Per l'installazione, attenersi alle norme in vigore nel paese di utilizzo del Washlet. 	<p>Ventilatore o apertura di ventilazione</p>  <p>Quadro elettrico 0,60 m</p> <p>Interruttore differenziale (salvavita)</p>
 Vietato	<ul style="list-style-type: none"> • Utilizzare esclusivamente acqua del rubinetto o acqua sotterranea potabile. (Utilizzando acque di provenienza diversa si potrebbero verificare infiammazioni cutanee o altri problemi.) • Non utilizzare il prodotto con caratteristiche di alimentazione diverse da quanto specificato (220-240 V CA, 50 Hz). (In caso di mancata osservanza di questa indicazione si potrebbero verificare incendi o scosse elettriche.) 	

⚠ ATTENZIONE



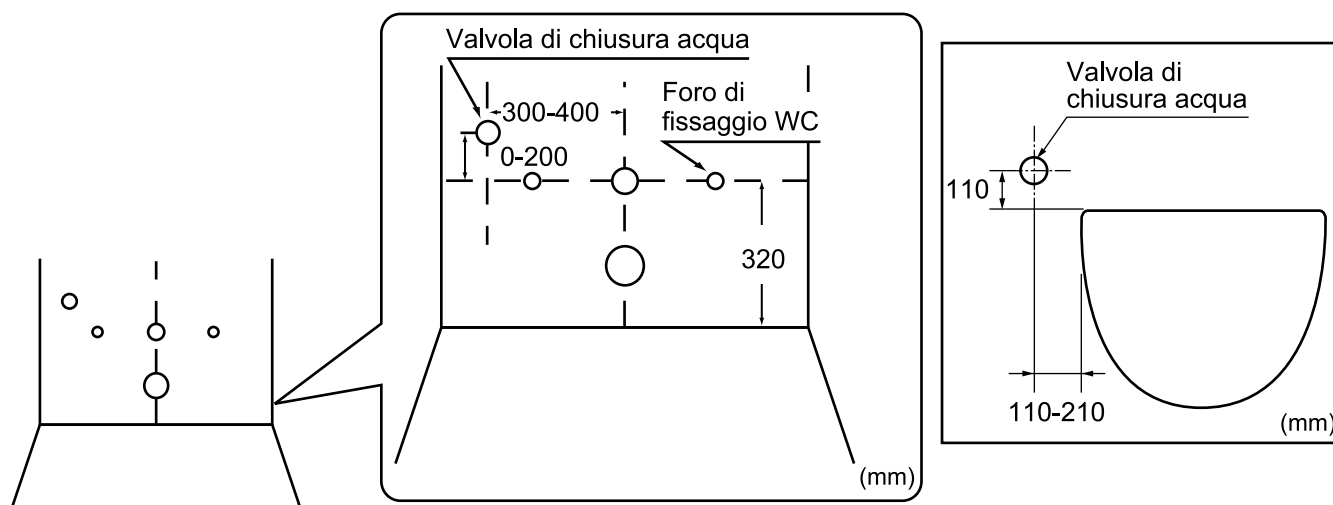

 Obbligatorio	<ul style="list-style-type: none"> • Dopo aver pulito il filtro dell'acqua, stringere a fondo la valvola di scarico con filtro dell'acqua incorporato. (In caso di mancata osservanza di questa indicazione si potrebbero verificare fuoriuscite d'acqua.)
	<ul style="list-style-type: none"> • Durante l'installazione, attenersi scrupolosamente al Manuale di installazione. (Se i collegamenti idraulici non vengono eseguiti correttamente, si potrebbero verificare fuoriuscite d'acqua.)
 Vietato	<ul style="list-style-type: none"> • Non staccare la valvola di scarico con filtro dell'acqua incorporato mentre la valvola di chiusura acqua è ancora aperta. (In caso contrario, si avrà una fuoriuscita di acqua.)
	<ul style="list-style-type: none"> • Non piegare o schiacciare il tubo flessibile di ingresso acqua. (In caso contrario, si potrebbero verificare fuoriuscite di acqua.)
	<ul style="list-style-type: none"> • Non sollevare il Washlet afferrando il sedile o il coperchio del WC. (Se l'unità principale del Washlet dovesse spostarsi e cadere, si potrebbero verificare infortuni.)

Prima di installare il Washlet

1. Non dare corrente all'apparecchio e non attivare l'erogazione dell'acqua finché l'installazione non sarà completata.
2. Fare attenzione a non danneggiare le parti collegate all'estremità del tubo flessibile di ingresso acqua.
3. La tensione di alimentazione è pari a 220-240 V CA (50 Hz). L'assorbimento nominale è di 274-319 W. Utilizzare cavi e prese adatti a questi valori di potenza. (Si raccomanda di eseguire cablaggi indipendenti.)
4. Non installare la base di appoggio sul Washlet prima di avere eseguito il fissaggio alla tazza. (Se si accende il Washlet in tali condizioni, si rischia di danneggiarlo.)
5. Il cavo di alimentazione ha una lunghezza di circa 0,9 m. Verificare che sia presente una presa elettrica nelle vicinanze per agevolare l'installazione e la rimozione del Washlet.
6. Collegare a una rete idraulica con pressione compresa tra 0,1 e 1,0 Mpa.
7. La temperatura dell'acqua deve essere compresa tra 0 e 35°C.
8. Il tubo flessibile di collegamento è lungo 0,5 m. L'ingresso dell'acqua deve trovarsi in posizione tale da agevolare l'installazione e la rimozione del Washlet.
9. Prima di installare il Washlet, verificare che l'erogazione dell'acqua sia controllata.

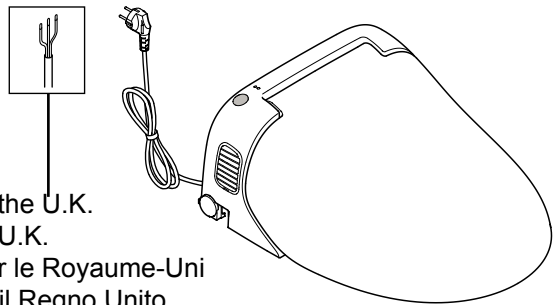
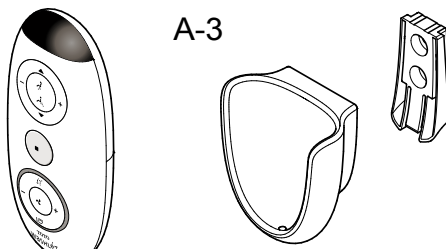

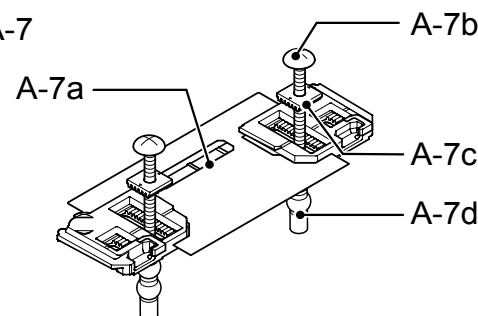
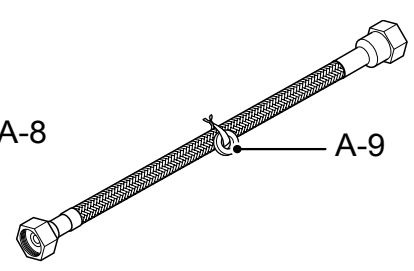
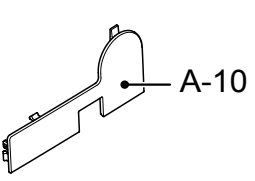
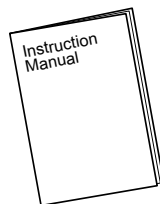
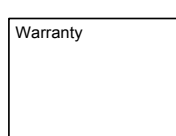
Included parts / Mitgelieferte Teile / Pièces fournies / Parti in dotazione

<p>A-1</p>  <p>For the U.K. Für U.K. Pour le Royaume-Uni Per il Regno Unito</p>	<p>A-2 A-3</p>  <p>A-4 A-5 A-6</p> 	
<p>A-7</p> 	<p>Anti-theft Installation Instructions Installationsanweisungen für Diebstahlschutz Les pièces antivols de la télécommande sont fournies dans le même emballage Istruzioni di installazione antifurto</p> <ul style="list-style-type: none"> • The anti-theft parts for remote control are supplied in the same package. Be sure to assemble them after asking the customer's need. If they are not used, hand them to the customer without fail. • Die Diebstahlschutzteile für die Fernbedienung gehören zum Lieferumfang. Diese sind nach Feststellen der Wünsche des Kunden unbedingt entsprechend zu montieren und müssen bei Nichtverwendung dem Kunden ausgehändigt werden. • Veuillez à bien les assembler après avoir demandé les besoins du client. Si elles ne sont pas utilisées, ne manquez pas de les remettre au client. • Le parti antifurto per il telecomando sono fornite nella stessa confezione. Assicurarsi di assemblarle dopo averne richiesto al cliente la necessità. Qualora esse non vengano utilizzate, non mancare di consegnarle al cliente. 	
<p>A-8</p>  <p>A-9</p>	<p>A-10</p> 	
<p>A-11</p>  <p>Instruction Manual Bedienungsanleitung Manuel d'instructions Manuale di istruzioni</p>	<p>A-12</p>  <p>Warranty Garantie Garantie Garanzia</p>	<p>A-13</p>  <p>Installation Guide Installationsanleitung Guide d'installation Manuale di installazione</p>

Available separately

- Please request the separate accessory set for use with a floor-mounted toilet.

Separat erhältlich

- Bestellen Sie für eine bodenmontierte Toilette bitte den separaten Zubehörsatz.

Disponibile séparément

- Veuillez demander le jeu d'accessoires distinct à utiliser avec des toilettes fixées au sol.

Accessori in vendita separatamente

- Per l'installazione su un WC da terra, richiedere l'apposito set di accessori.

Required tools / Erforderliches Werkzeug / Outils requis / Utensili richiesti

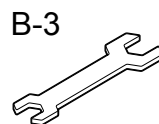
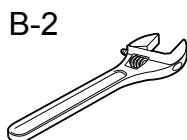
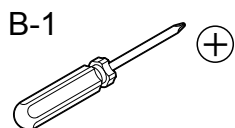

B-4

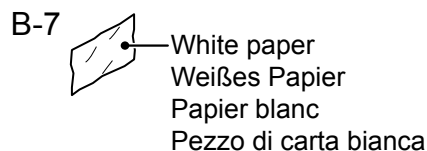
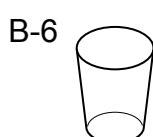
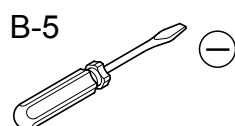
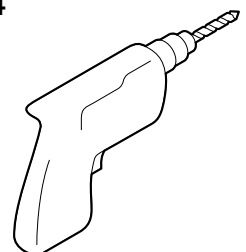



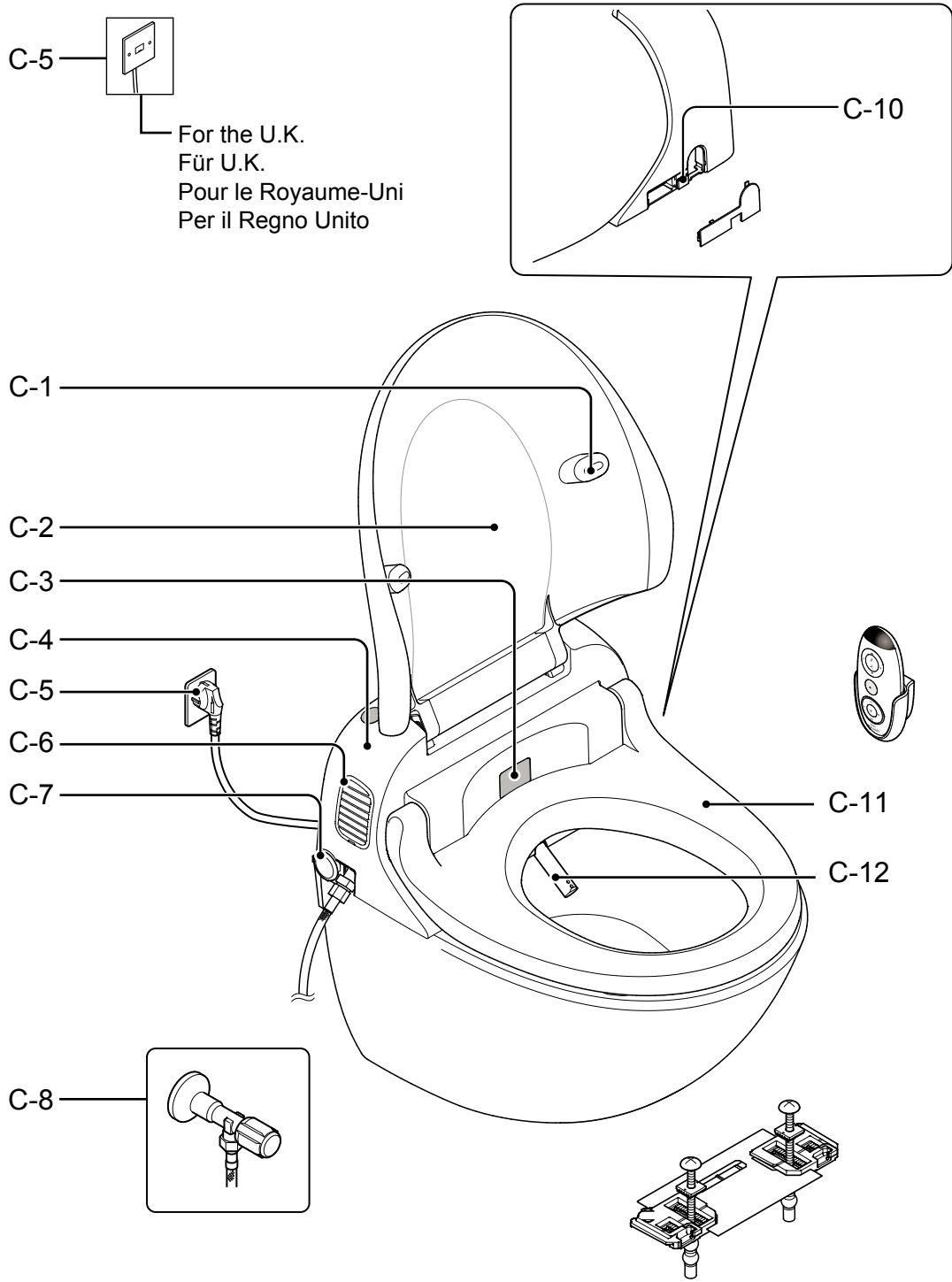

Parts / Teile / Pièces / Parti







Meaning of the indications
Bedeutung der Hinweise
Signification des indications
Significato delle indicazioni





GB

-  : Task that must be conducted by the installer
-  : Action that the Washlet should perform automatically
-  : Work that requires confirmation
-  : Shows the work sequence





DE

-  : Diese Aufgabe ist vom Installateur auszuführen
-  : Diese Funktion wird vom Washlet automatisch ausgeführt
-  : Bei dieser Tätigkeit ist eine Bestätigung erforderlich
-  : Zeigt den Arbeitsablauf an

FR

-  : Tâche incombant à l'installateur
-  : Action que le Washlet doit exécuter automatiquement
-  : Tâche exigeant une vérification
-  : Indique l'ordre de suivi de la procédure

IT

-  : operazione che deve essere eseguita dall'installatore
-  : operazione che il Washlet dovrebbe eseguire automaticamente
-  : intervento che deve essere preceduto da verifiche
-  : indica la sequenza di lavoro

Installing the Washlet
Installation des Washlets
Installation du Washlet
Installazione del Washlet

1

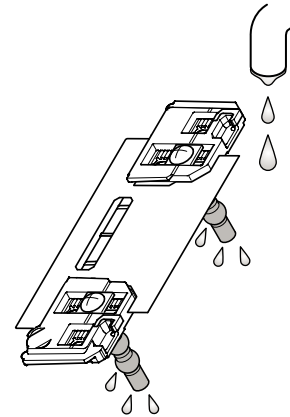

2

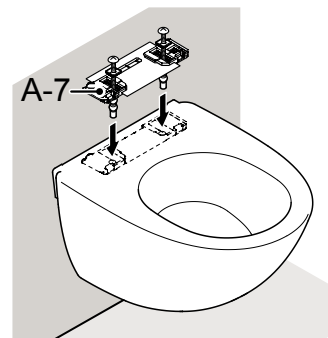

3

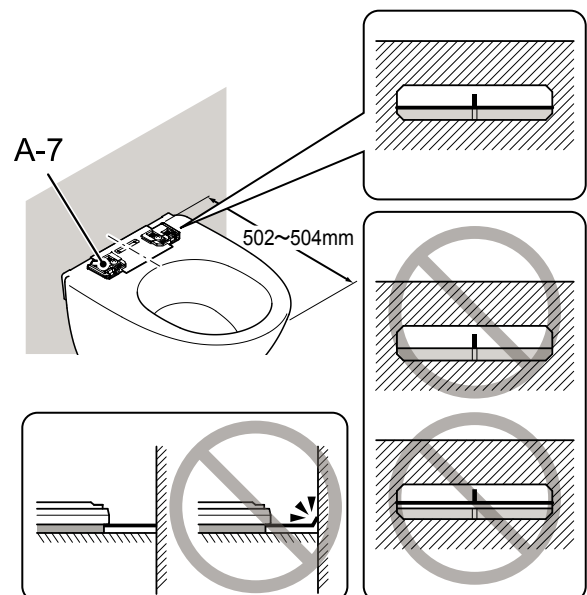

4

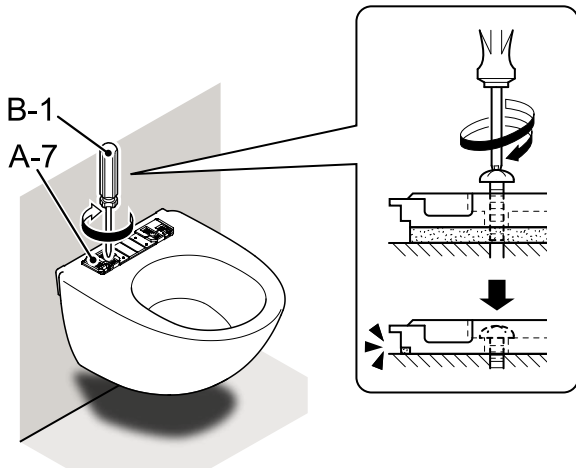

5

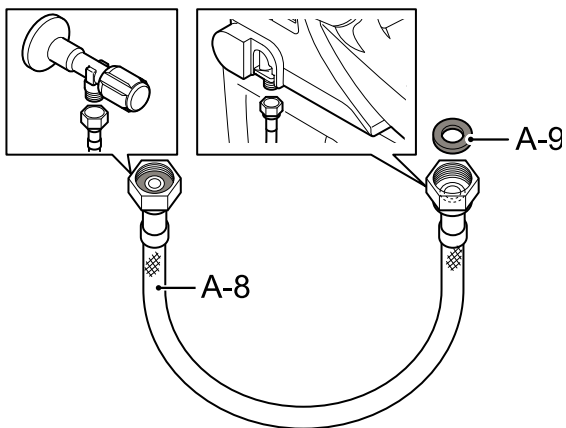

6

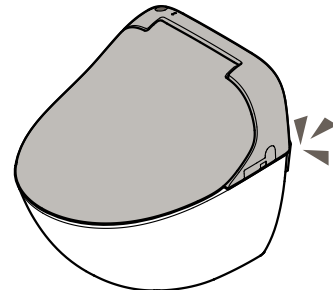
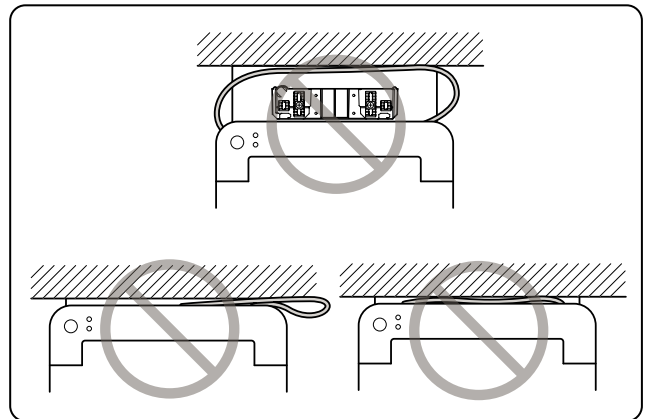
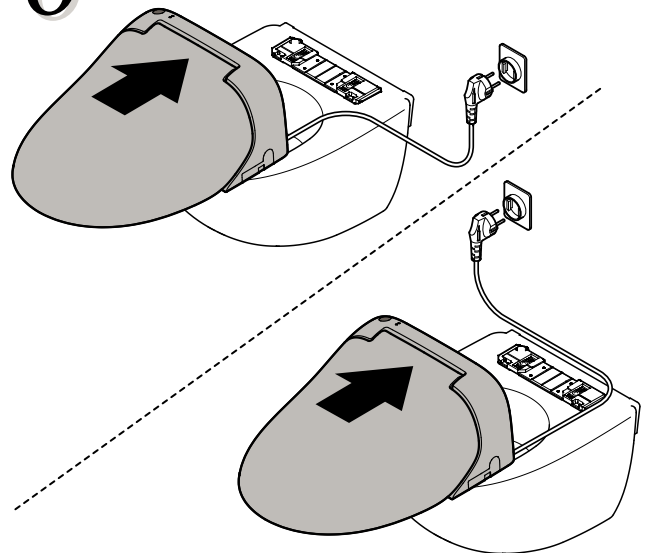

GB

Press the washlet body into the base plate until it clicks into place. (After attaching it, confirm that the washlet body cannot be detached even if pulled.)

DE

Drücken Sie den Korpus des Washlet in die Auflageplatte, bis er mit einem Klicken einrastet. (Stellen Sie nach der Anbringung sicher, dass sich der Korpus des Washlet nicht lösen lässt, selbst wenn Sie daran ziehen.)

FR

Enfoncez le corps du Washlet dans le socle jusqu'à ce qu'il s'enclenche avec un déclic.

(Une fois fixé, assurez-vous que le corps du Washlet ne peut plus être retiré, même en tirant dessus.)

IT

Spingere il Washlet nella base di appoggio finché non scatta in posizione. (Dopo averlo montato, accertarsi che il Washlet non possa essere staccato anche se tirato.)

7

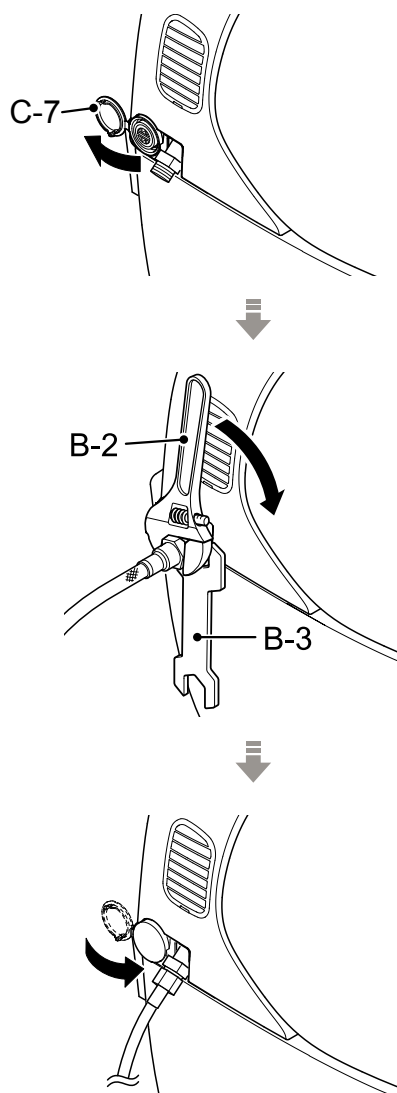

[GB]

⚠ CAUTION



Required

Fix the water supply input using a spanner, and connect the water supply hose.

- An excessive force may damage the water supply input and water leaks could occur.

[DE]

⚠ VORSICHT



Erforderlich

Befestigen Sie den Wasserzulauf mit Hilfe eines Schraubenschlüssels und schließen Sie den Wasserzulaufschlauch an.

- Übermäßige Krafteinwirkung kann den Wasserzulauf beschädigen, wodurch möglicherweise undichte Stellen entstehen.

[FR]

⚠ MISE EN GARDE



Requis

Fixez l'entrée de l'alimentation en eau à l'aide d'une clé à écrous et branchez le flexible d'alimentation en eau.

- Une force excessive pourrait endommager l'entrée de l'alimentation en eau et des fuites pourraient se produire.

[IT]

⚠ ATTENZIONE



Obbligatorio

Fissare il raccordo di ingresso acqua con una chiave inglese, e collegare il tubo flessibile di ingresso acqua.

- Esercitando una forza eccessiva si rischia di danneggiare il raccordo di ingresso acqua, pertanto potrebbero verificarsi perdite.

8

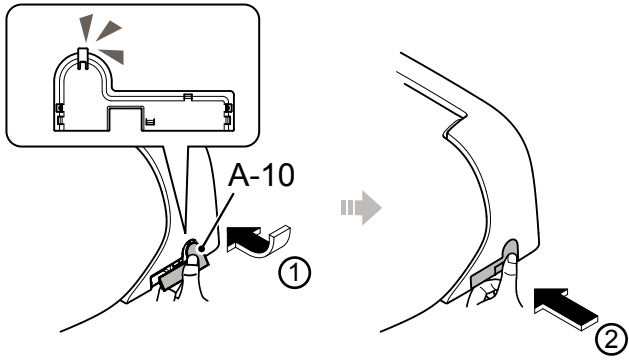

9

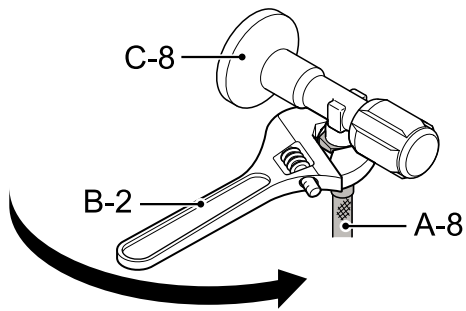

10

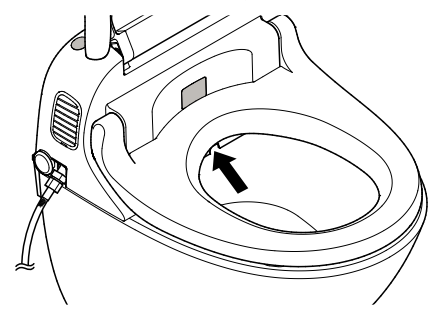
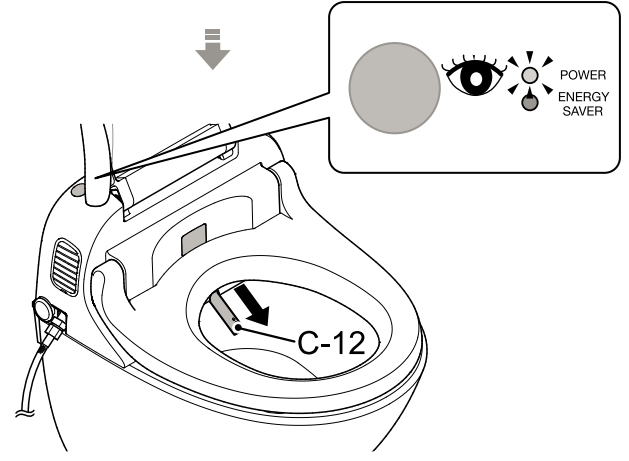
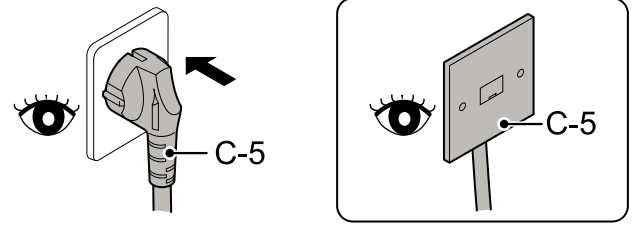
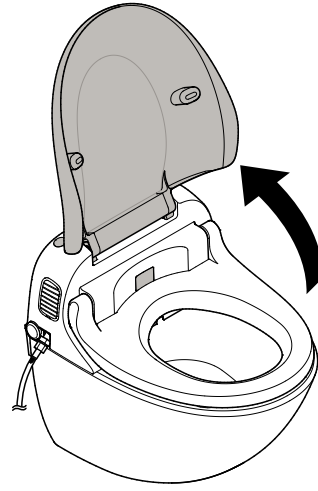

11

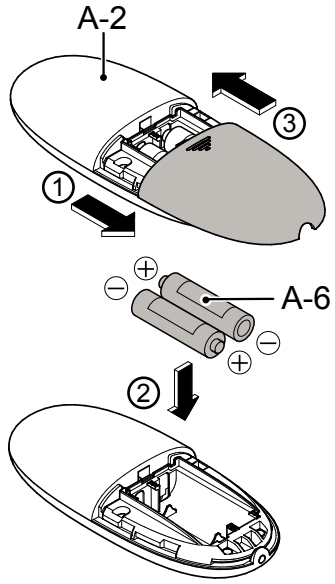

12

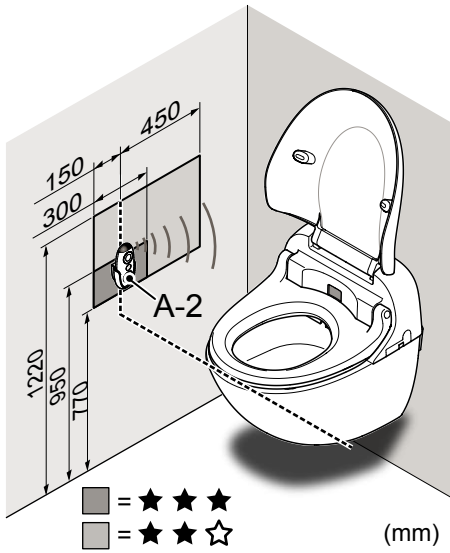

13

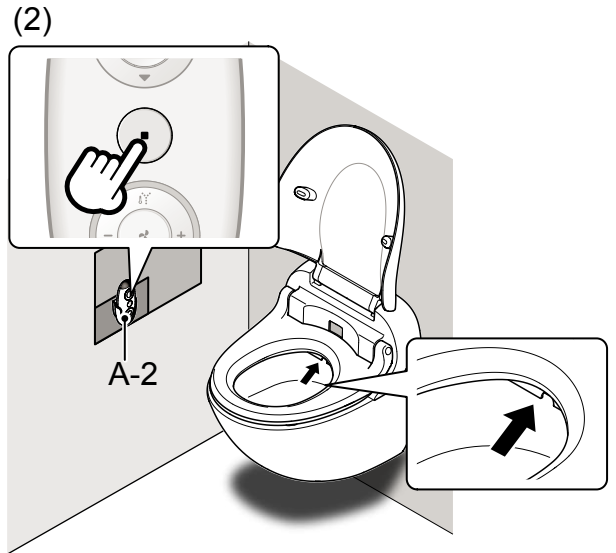
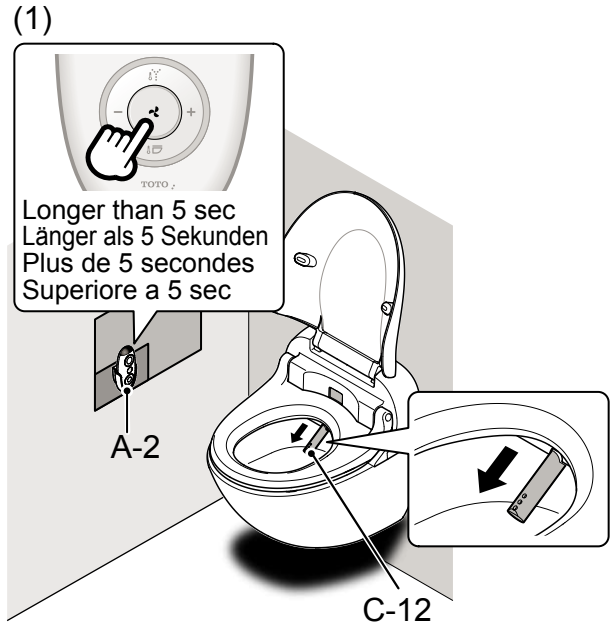

14

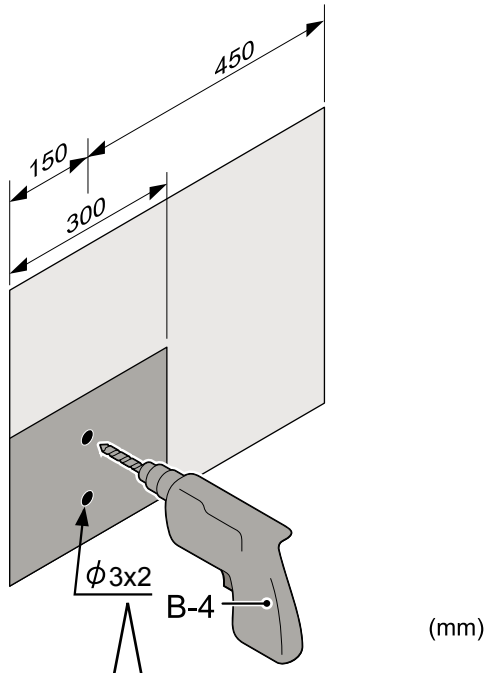

(mm)

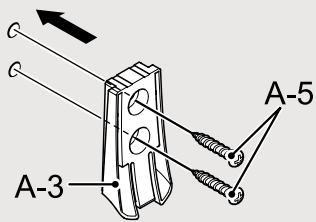

With a plasterboard or tile wall.

An Gipskartonplatten oder Fliesen.

Pour un mur en plaques de plâtre ou en carrelage.

Con parete in cartongesso o piastrellata.

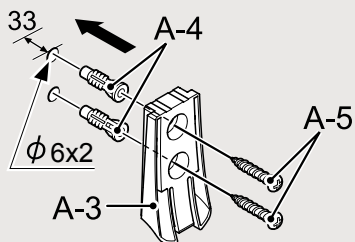

(mm)

15

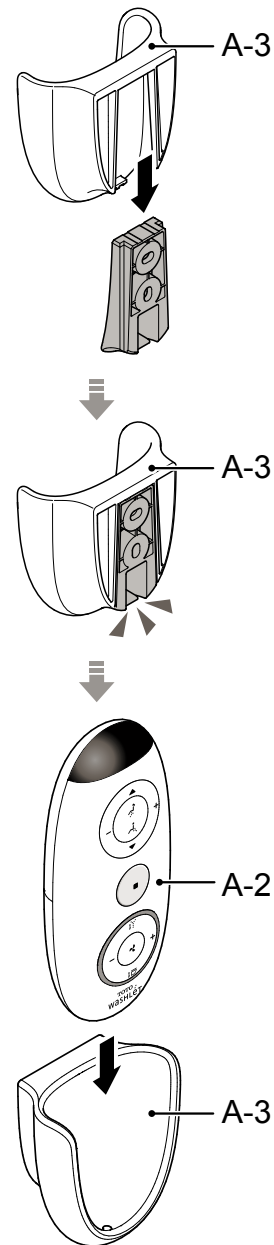

GB

As for the procedure of how to mount the anti-theft parts, please refer to the instruction manual in the same package.

DE

Das Verfahren zum Einbau der Diebstahlschutzteile ist in der mitgelieferten Installationsanleitung beschrieben.

FR

En ce qui concerne la procédure de montage des pièces antivol, veuillez vous reporter au manuel d'instructions contenu dans le même emballage.

IT

Per la procedura sul montaggio delle parti antifurto, si prega di fare riferimento al manuale di istruzioni fornito nella stessa confezione.

When you want to remove the remote control hanger.

Bei gewünschtem Ausbau des Fernbedienungshalters.

Lorsque vous voulez retirer le support de tÉlÉcommande.

Quando si desidera rimuovere il portatelecomando.

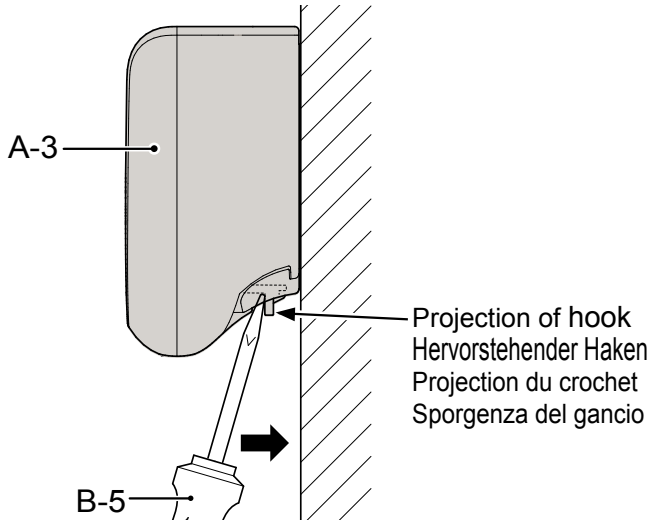

Testing the operation of the Washlet Funktionstest des Washlets Test du fonctionnement du Washlet Prova di funzionamento del Washlet

1

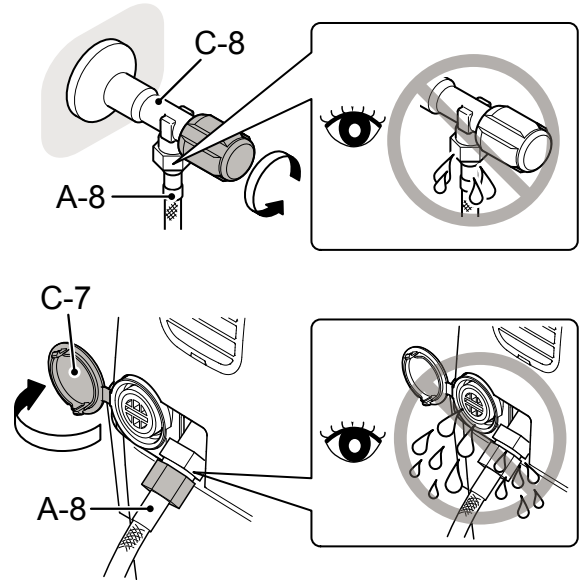

2

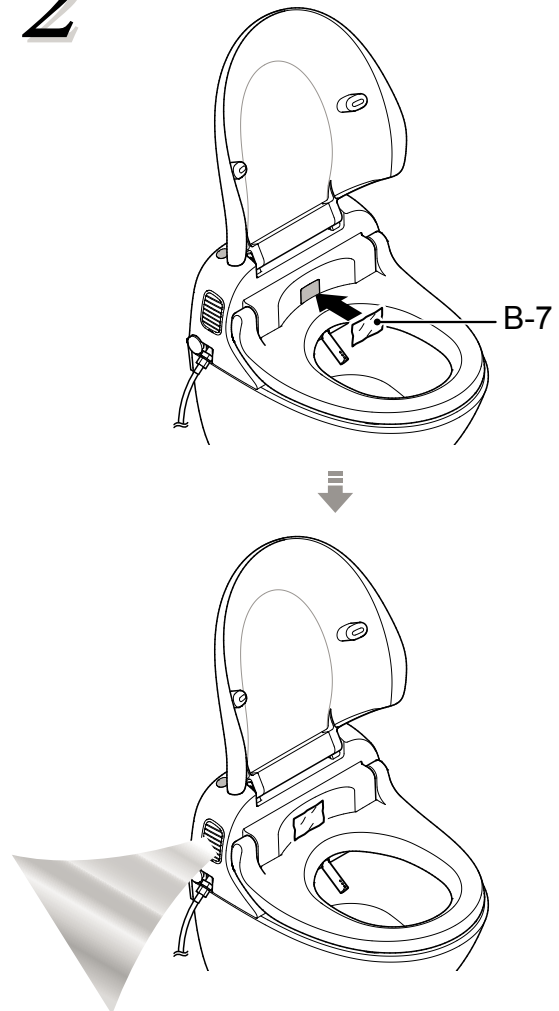

3

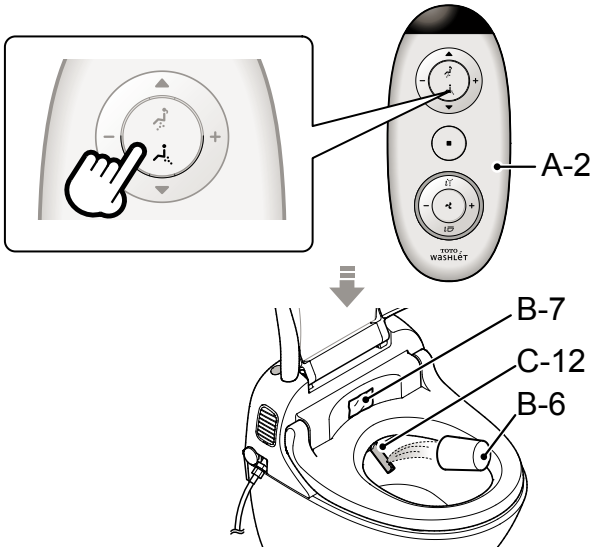

4

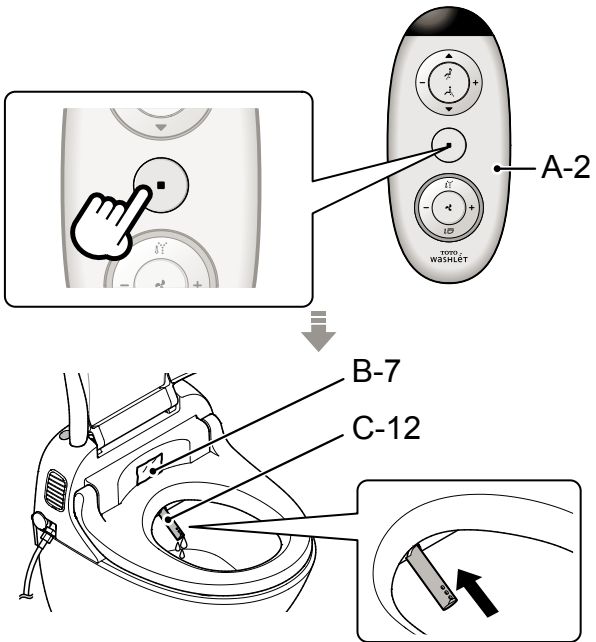

5

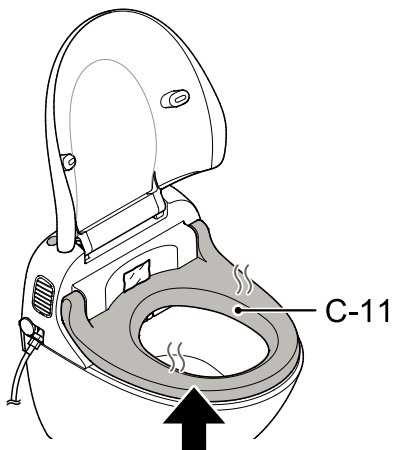

©TOTO Ltd. All rights reserved.
©TOTO Ltd. Alle Rechte vorbehalten.
©TOTO Ltd. Tous droits réservés.
©TOTO Ltd. Tutti i diritti riservati.

2009. 12. 25
D08324
Printed in Japan.
Gedruckt in Japan.
Imprimé au Japon.
Stampato in Giappone.