

WH183EAT

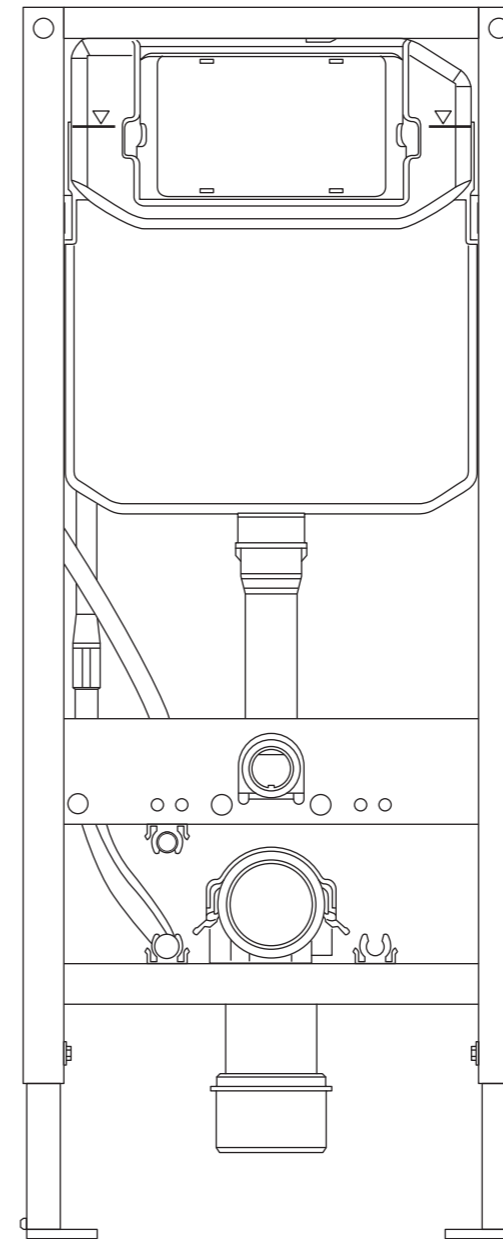



Cautions and warnings / Vorsichtsmaßnahmen und Warnungen / Mises en garde et avertissements / Precauzioni e avvertenze	P.2 P.4 P.6 P.8
Included Parts Mitgelieferte Teile Pièces fournies Parti incluse	P.10
Before Installation Vor der Installation Avant l'installation Prima dell'installazione	P.11
Flow of installation Ablauf der Installation Processus d'installation Procedura di installazione	P.12
Installation procedure Installationsverfahren Procédure d'installation Procedura di installazione	P.12
Servicing procedures Wartungsverfahren Procédures de réparation Procedura di manutenzione	P.28
Cleaning the Filter of the Fill Valve Reinigung des Füllventilfilters Nettoyage du filtre de la vanne de remplissage Pulizia del filtro della valvola di riempimento	P.30

Perform the installation work properly according to this Installation Guide so that the product can function well. After installation, fully explain how to use it to your customer.



Cautions and warnings (Always observe these warnings.)







Before installation, read these "Cautions and warnings" carefully and attach the equipment correctly. This manual uses various indications to guide safe installation of the product and to prevent injury to customers or other people and damage to property. This product should be installed by a professional. The indications and their meanings are as follows.

Symbol example	Meaning of symbol
 WARNING	This indication means the case where there is a possible danger which may result in death or serious injury if the product is used improperly.
 CAUTION	This indicates that misoperation could result in injury or physical damage.

The following symbols are used to classify and explain instructions that must be followed.

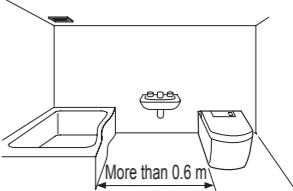
	The  symbol indicates something that is prohibited.		The  symbol indicates something that must be done.
---	--	---	---



 WARNING	
 Prohibited	<ul style="list-style-type: none"> Do not use any power supply other than the one specified Do not use damaged power cords, electric wiring, or connections Do not use power cords or electric wiring with loose connections (Failure to do so may cause fire or electrical shock.)
	<ul style="list-style-type: none"> Do not install the power supply connection directly beneath the water supply position, or allow the water supply hose to touch the power supply connection (Condensation or the like could cause the power supply connection to become wet, causing fire or electrical shock.)
	<ul style="list-style-type: none"> Do not strike, yank, twist, excessively bend, damage, alter, or heat the power cord, electric wiring, and connections. Also, do not place anything heavy on, bind, or pinch the power cord, electric wiring, and connections (Using a damaged part may result in fire, electrical shock, heat, or a short circuit.)
	<ul style="list-style-type: none"> Do not remove or install while the power is on or while water is supplied to the main unit (Doing so may cause electrical shock or malfunction.)
	<ul style="list-style-type: none"> Do not install the product in open air, on slanted wall or in a place exposed to thumping vibration (The installation may become unstable and the product may fall and cause injury.)
 Be sure to follow	<ul style="list-style-type: none"> In accordance with the laws and standards of the area where you use it, do not use anything other than tap water or well water (Doing so may cause irritation to the skin and malfunction.)
	<ul style="list-style-type: none"> The installation has to be in accordance with the local standard
	<ul style="list-style-type: none"> Always connect the product to the cold water supply Be sure to hold the frame when carrying the product body (Failure to do so may result in burns and equipment malfunction.) (If you hold other part, the product may be broken, resulting in injury, physical damage or water leak.)

 WARNING	
 Be sure to follow	<ul style="list-style-type: none"> Check that an appropriate ground is installed For the ground, use copper wire with a ground resistance of no more than 100 and a diameter of at least 0.06 in (1.6 mm) If there is no ground installed, ask the contractor who did the installation to install the ground (Failure to install a ground may result in electrical shock if there is a malfunction or current leak.)
	<ul style="list-style-type: none"> Check that the connections of the power supply and electric wiring are connected properly Be sure to connect to an earth leakage circuit breaker using power supply equipment equipped with a ground Install this product in accordance with installation and electrical work restrictions for the corresponding country If the wiring has not been completed, ask the contractor who did the installation to do it (Failure to do so may cause fire or electrical shock.)
	<ul style="list-style-type: none"> Install the power supply equipment (device) and its connections at least 0.60 m away from the edge of the shower tub or bathtub (Failure to do so may cause fire or electrical shock.)
	 <p>Install a earth leakage circuit breaker or insulation transformer.</p>
 Do not disassemble	<ul style="list-style-type: none"> If the power cord is damaged, avoid danger by having the manufacturer's repair department or equivalent specialist replace it (Failure to do so may cause electrical shock.)
	<ul style="list-style-type: none"> Check that the wires are connected properly (Otherwise, the device may malfunction.)
	<ul style="list-style-type: none"> People other than technicians should never disassemble, repair, or alter the product (Doing so may cause a malfunction, electrical shock, or injury.)
 CAUTION	
 Prohibited	<ul style="list-style-type: none"> Do not fold or crush the water supply hose; do not damage by cutting with a sharp object (Doing so may cause water leaks.)
	<ul style="list-style-type: none"> Do not remove the drain valve or fill valve while the shutoff valve is open (Doing so will cause water to spurt out.)
	<ul style="list-style-type: none"> Do not give direct to the product (Otherwise, the product may be broken, resulting in injury, physical damage or water leak.)
 Be sure to follow	<ul style="list-style-type: none"> Carry out the installation according to the Installation Guide (Failure to install properly it may cause water leaks, electrical shock, or fire.)
	<ul style="list-style-type: none"> Be sure to use the included or specified parts for installation work (Otherwise, the product may not be installed properly.)

Führen Sie die Installationsarbeiten entsprechend dieser Anleitung durch, um sicherzustellen, dass das Produkt richtig funktioniert. Geben Sie dem Kunden nach der Installation genaue Anweisungen zur Benutzung.



Vorsichtsmaßnahmen und Warnungen (Beachten Sie diese Warnungen immer.)





Bitte lesen Sie diese "Vorsichtsmaßnahmen und Warnungen" vor der Installation aufmerksam durch und bringen Sie das Produkt entsprechend an. Diese Anleitung enthält zahlreiche Hinweise zur sicheren Installation des Produkts sowie Anmerkungen, wie Sie Verletzungen und Schäden vermeiden können. Das Produkt sollte durch einen professionellen Installateur eingebaut werden. Die Hinweise und ihre Bedeutung sind im Folgenden erklärt.



Symbol-Beispiel	Bedeutung des Symbols
 WARNUNG	Dies weist darauf hin, dass eine falsche Bedienung des Produkts zum Tod oder zu schweren Verletzungen führen kann.
 VORSICHT	Dies weist darauf hin, dass eine falsche Bedienung zu körperlichen Verletzungen oder Sachschäden führen kann.

Die folgenden Symbole werden verwendet, um die zu befolgenden Anweisungen zu klassifizieren und zu erläutern.

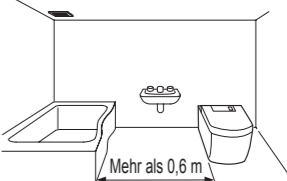
	Mit  werden verbotene Arbeitsinhalte gekennzeichnet.		Mit  werden unbedingt auszuführende Arbeitsinhalte gekennzeichnet.
---	---	---	---

 WARNUNG	
 Verboten	<ul style="list-style-type: none"> •Verwenden Sie nur die angegebene Stromversorgung •Verwenden Sie keine beschädigten Netzkabel, elektrische Verkabelungen oder Anschlüsse •Verwenden Sie keine Netzkabel oder elektrische Verkabelungen mit losen Anschlüssen (Andernfalls kann ein Brand oder elektrischer Schlag ausgelöst werden.)
	<ul style="list-style-type: none"> •Installieren Sie den Stromanschluss nicht direkt unter der Wasserversorgung und achten Sie darauf, dass der Wasserschlauch den Stromanschluss nicht berührt (Kondensation oder ähnliches kann dazu führen, dass der Anschluss der Stromversorgung nass wird. Dies kann Brände oder elektrische Schläge auslösen.)
	<ul style="list-style-type: none"> •Achten Sie darauf, dass das Netzkabel, die elektrische Verkabelung und die Anschlüsse nicht gestoßen, verdreht, stark gebogen, beschädigt, verändert oder erhitzt werden. Stellen Sie auch keine schweren Gegenstände auf das Netzkabel, die elektrische Verkabelung und die Anschlüsse und binden oder klemmen Sie sie nicht (Die Verwendung eines beschädigten Teils kann zu Bränden, elektrischen Schlägen, Wärmeentwicklung oder einem Kurzschluss führen.)
	<ul style="list-style-type: none"> •Entfernen oder installieren Sie das Gerät nicht, solange das Gerät eingeschaltet ist oder Wasser in die Haupteinheit geleitet wird (Andernfalls kann es zu elektrischen Schlägen oder Fehlfunktionen kommen.)
	<ul style="list-style-type: none"> •Installieren Sie das Produkt nicht im Freien, an einer schrägen Wand oder an einem Ort, der starken Vibrationen ausgesetzt ist (Die Installation kann instabil werden und das Produkt kann herunterfallen und Verletzungen verursachen.)
 Unbedingt beachten	<ul style="list-style-type: none"> •Verwenden Sie in Übereinstimmung mit den Gesetzen und Normen des Gebiets, in dem Sie es verwenden, nichts anderes als Leitungswasser oder Brunnenwasser (Andernfalls kann es zu Hautreizungen und Fehlfunktionen kommen.)
	<ul style="list-style-type: none"> •Der Einbau muss gemäß den örtlichen Vorschriften erfolgen
	<ul style="list-style-type: none"> •Schließen Sie das Produkt immer an die Kaltwasserversorgung an (Andernfalls kann es zu Verbrennungen und Fehlfunktionen des Geräts kommen.)
	<ul style="list-style-type: none"> •Achten Sie darauf, das Produkt beim tragen am Rahmen zu halten (Wenn Sie es an einem anderen Teil halten, kann das Produkt beschädigt werden, was Verletzungen, Sachschäden oder Wasserlecks zur Folge haben kann.)

 WARNUNG	
 Unbedingt beachten	<ul style="list-style-type: none"> •Achten Sie darauf, dass eine geeignete Erdung vorhanden ist •Verwenden Sie für die Erdung Kupferdraht mit einem Erdungswiderstand von nicht mehr als 100 Ω und einem Durchmesser von mindestens 1,6 mm (0,06 Zoll) •Wenn keine Erdung vorhanden ist, bitten Sie den Fachbetrieb, der die Installation durchgeführt hat, diese zu installieren (Wenn keine Erdung vorhanden ist, kann es bei Fehlfunktionen oder Stromausfall zu einem elektrischen Schlag kommen.)
	<ul style="list-style-type: none"> •Überprüfen Sie, dass die Anschlüsse der Stromversorgung und die elektrische Verkabelung ordnungsgemäß verbunden sind •Stellen Sie sicher, dass Sie einen Fehlerstromschutzschalter über eine Stromversorgungseinrichtung mit der Erdung verbinden •Installieren Sie dieses Produkt gemäß den Installations- und Elektroarbeitsbeschränkungen des jeweiligen Landes •Wenn die Verkabelung nicht vollständig abgeschlossen ist, bitten Sie den Fachbetrieb, der die Installation durchgeführt hat, dies zu tun (Andernfalls kann ein Brand oder elektrischer Schlag ausgelöst werden.)
	<ul style="list-style-type: none"> •Installieren Sie die Stromversorgungseinrichtung (Gerät) und die Anschlüsse mindestens 0,60 m vom Rand der Duschwanne oder der Badewanne entfernt (Andernfalls kann ein Brand oder elektrischer Schlag ausgelöst werden.) <div style="text-align: right;">  <p>Mehr als 0,6 m</p> <p>Installieren Sie einen Fehlerstromschutzschalter oder Trenntransformator.</p> </div>
	<ul style="list-style-type: none"> •Wenn das Netzkabel beschädigt ist, vermeiden Sie Gefahren, indem Sie es vom Reparaturdienst des Herstellers oder einem entsprechenden Sachverständigen ersetzen lassen. (Andernfalls kann ein elektrischer Schlag ausgelöst werden.)
 Nicht demontieren	<ul style="list-style-type: none"> •Achten Sie darauf, dass die Drähte ordnungsgemäß angeschlossen sind (Andernfalls kann es zu Fehlfunktionen des Geräts kommen.)
	<ul style="list-style-type: none"> •Das Produkt darf nur von fachkundigen Personen demontiert, repariert oder modifiziert werden. (Andernfalls kann es zu Funktionsstörungen, elektrischen Schlägen oder Verletzungen kommen.)



 VORSICHT	
 Verboten	<ul style="list-style-type: none"> •Knicken oder quetschen Sie den Wasserversorgungsschlauch nicht; nicht durch Schneiden mit einem scharfen Gegenstand beschädigen (Dies kann zu Wasserlecks führen.)
	<ul style="list-style-type: none"> •Entfernen Sie das Ablass- oder Füllventil nicht, während das Absperrventil geöffnet ist (Dadurch spritzt Wasser heraus.)
	<ul style="list-style-type: none"> •Nicht direkt auf das Produkt drücken (Das Produkt könnte sonst beschädigt werden, was Verletzungen, Sachschäden oder Wasserlecks zur Folge haben kann.)
 Unbedingt beachten	<ul style="list-style-type: none"> •Bitte führen Sie die Installationsarbeiten der Anleitung folgend aus (Andernfalls könnte es zu Wasserlecks kommen.)
	<ul style="list-style-type: none"> •Verwenden Sie für die Installationsarbeiten unbedingt die mitgelieferten bzw. vorgeschriebenen Teile (Andernfalls besteht die Möglichkeit, dass eine ordnungsgemäße Installation nicht möglich ist.)

Exécutez correctement l'installation en suivant ces instructions de montage afin de vous assurer que le produit fonctionne convenablement. Une fois l'installation terminée, donnez des instructions précises au client.

Mises en garde et avertissements (veuillez toujours respecter ces avertissements.)





Avant l'installation, lisez attentivement les "Mises en garde et avertissements" et montez convenablement l'appareil. Ces instructions de montage contiennent diverses indications pour une installation sûre du produit et pour éviter toute blessure et tout dommage.







Ce produit doit être installé par un professionnel. Les indications et leurs significations sont expliquées ci-après.

Exemple de symbole	Signification du symbole
 AVERTISSEMENT	Signale une situation dans laquelle un dommage pouvant entraîner la mort ou des blessures graves existe si le produit n'est pas utilisé correctement.
 MISE EN GARDE	Ce symbole indique que toute utilisation incorrecte peut entraîner des blessures ou des dommages matériels.

Les articles devant être observés sont classés par type et sont expliqués au moyen des pictogrammes suivants.

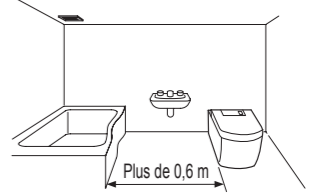
	Le symbole  indique quelque chose d'interdit.		Le symbole  indique que quelque chose doit être fait.
---	--	---	---



 AVERTISSEMENT	
 Interdit	<ul style="list-style-type: none"> • N'utilisez aucune autre alimentation que celle spécifiée • N'utilisez pas de câbles d'alimentation, câblage électrique ou prises endommagés • N'utilisez pas de câbles d'alimentation ou de câblage électrique aux prises instables <p>(Dans le cas contraire, il pourrait en résulter des risques d'incendie ou de décharge électrique.)</p>
	<ul style="list-style-type: none"> • Ne heurtez pas le câble d'alimentation, le câblage électrique et les prises, ne tirez pas dessus, ne les pliez pas excessivement, ne les endommagez pas, ne les modifiez pas et ne les chauffez pas. De plus, ne placez aucun objet lourd dessus, n'attachez pas et ne pincez pas le câble d'alimentation, le câblage électrique et les prises <p>(La condensation ou des conditions similaires peuvent mouiller la prise d'alimentation électrique et entraîner des risques d'incendie ou de décharge électrique.)</p>
	<ul style="list-style-type: none"> • Ne frappez pas, ne tirez pas, ne tordez pas, ne pliez pas excessivement, n'endommagez pas, ne modifiez pas ou ne chauffez pas le cordon d'alimentation, le câblage électrique et les connexions. De plus, ne placez rien de lourd sur, ne coincez pas ou ne coincez pas le cordon d'alimentation, le câblage électrique et les connexions. , Ne faites rien qui puisse endommager <p>(L'utilisation d'une pièce endommagée peut entraîner un risque d'incendie, de décharge électrique ou de court-circuit.)</p>
	<ul style="list-style-type: none"> • Ne procédez pas à la suppression ou à l'installation lorsque le système est sous tension ou pendant l'alimentation en eau de l'unité principale <p>(Cela pourrait entraîner une décharge électrique ou un dysfonctionnement.)</p>
	<ul style="list-style-type: none"> • N'installez pas le produit à l'air libre, sur un mur incliné ou dans un endroit exposé à des vibrations fortes <p>(L'installation peut devenir instable et le produit peut tomber et provoquer des blessures.)</p>
 À suivre impérativement	<ul style="list-style-type: none"> • Conformément aux lois et normes de la région où vous l'utilisez, n'utilisez rien d'autre que de l'eau du robinet ou de l'eau de puits <p>(Cela pourrait provoquer une irritation de la peau et un dysfonctionnement.)</p>
	<ul style="list-style-type: none"> • L'installation doit être conforme à la réglementation locale
	<ul style="list-style-type: none"> • Branchez toujours le produit à l'arrivée d'eau froide <p>(Dans le cas contraire, il pourrait en résulter des brûlures ou un dysfonctionnement de l'équipement.)</p>
 À suivre impérativement	<ul style="list-style-type: none"> • Veillez à tenir le châssis lors du transport du corps du produit <p>(Si vous le tenez par une autre partie, le produit pourrait casser, entraînant des blessures, des dommages matériels ou une fuite d'eau.)</p>

 AVERTISSEMENT	
 À suivre impérativement	<ul style="list-style-type: none"> • Vérifiez qu'une prise de terre adéquate est installée. • Pour la prise de terre, utilisez un câble de cuivre d'une résistance de 100 Q maximum et d'un diamètre d'au moins 1,6 mm • Si aucune prise de terre n'est installée, demandez au professionnel responsable de l'installation de l'installer <p>(L'absence d'une prise de terre peut entraîner une décharge électrique en cas de dysfonctionnement ou de fuite de courant.)</p>
	<ul style="list-style-type: none"> • Vérifiez que l'alimentation électrique et le câblage électrique sont correctement raccordés • Assurez-vous que la prise est reliée à un disjoncteur à courant de défaut à l'aide du matériel d'alimentation électrique intégrant une prise de terre • Installez ce produit conformément aux restrictions électriques et d'installation du pays correspondant • Si le câblage n'a pas été réalisé, demandez au professionnel responsable de l'installation de s'en occuper <p>(Dans le cas contraire, il pourrait en résulter des risques d'incendie ou de décharge électrique.)</p>
	<ul style="list-style-type: none"> • Installez le matériel d'alimentation électrique (appareil) et ses prises à au moins 0,60 m du bord de la douche ou de la baignoire <p>(Dans le cas contraire, il pourrait en résulter des risques d'incendie ou de décharge électrique.)</p>
	 <p>Plus de 0,6 m</p> <p>Installez un interrupteur de fuite à la terre ou un transformateur d'isolement.</p>
 Ne pas démonter	<ul style="list-style-type: none"> • Si le câble d'alimentation est endommagé, évitez tout risque en demandant au service de réparation du fabricant ou à un spécialiste équivalent de le remplacer <p>(Dans le cas contraire, il pourrait en résulter des risques de décharge électrique.)</p>
	<ul style="list-style-type: none"> • Confirmez que les câbles sont correctement branchés <p>(Dans le cas contraire, l'appareil risque de ne pas fonctionner correctement.)</p>
	<ul style="list-style-type: none"> • Personne d'autre qu'un technicien ne doit démonter, réparer ou modifier le produit <p>(cela pourrait entraîner un mauvais fonctionnement, un choc électrique ou des blessures.)</p>
 MISE EN GARDE	
 Interdit	<ul style="list-style-type: none"> • Ne pas plier ou écraser le tuyau d'alimentation en eau ; ne pas endommager en coupant avec un objet pointu <p>(Cela pourrait provoquer des fuites d'eau.)</p>
	<ul style="list-style-type: none"> • Ne retirez pas la vanne de vidange ou la vanne de remplissage lorsque la vanne d'arrêt est ouverte <p>(Cela fera jaillir de l'eau.)</p>
	<ul style="list-style-type: none"> • Ne soumettez pas le produit à des chocs <p>(Dans le cas contraire, le produit pourrait casser, entraînant des blessures, des dommages matériels ou une fuite d'eau.)</p>
 À suivre impérativement	<ul style="list-style-type: none"> • Effectuez les travaux d'installation conformément à ces instructions de montage <p>(Sinon, des fuites d'eau peuvent survenir.)</p>
	<ul style="list-style-type: none"> • Veillez à bien utiliser les pièces spécifiées ou fournies pour les travaux d'installation <p>(Sinon, le produit peut ne pas être correctement installé.)</p>

Eeguire il lavoro di installazione correttamente seguendo questa Guida per l'installazione, in modo che il prodotto possa funzionare bene. Dopo l'installazione, spiegare completamente al vostro cliente come utilizzarlo.





Precauzioni e avvertenze (Osservare sempre queste avvertenze.)





Prima dell'installazione, si prega di leggere attentamente queste "Precauzioni e avvertenze" per un montaggio corretto dell'apparecchio. Questo manuale utilizza varie indicazioni per l'installazione sicura del prodotto e per la prevenzione di lesioni fisiche ai consumatori o altre persone, ed anche per danni materiali. Questo prodotto deve essere installato da un installatore professionale. Le indicazioni e i loro significati sono riportati come segue.



Indicazione	Significato del simbolo
 AVVERTENZA	Questa indicazione avvisa di un caso di possibile pericolo che può comportare morte o lesioni gravi qualora il prodotto non venisse utilizzato correttamente.
 ATTENZIONE	Questo indica che un'operazione errata può avere come conseguenza lesioni o danni fisici.

Le tipologie di voci da osservare sono classificate e spiegate da pittogrammi come viene riportato di seguito.

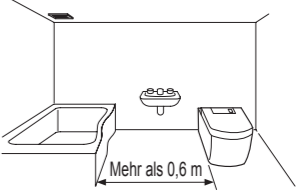
	 Il simbolo alla sinistra indica qualcosa che è proibito.		 Il simbolo alla sinistra indica qualcosa che deve essere eseguito.
---	--	---	--

 AVVERTENZA	
 Proibito	<ul style="list-style-type: none"> ● Non utilizzare un'alimentazione diversa da quella specificata ● Non utilizzare cavi di alimentazione, connessioni o cavi elettrici danneggiati ● Non utilizzare cavi di alimentazione o cavi elettrici con connessioni allentate (In caso contrario sussiste il rischio di incendio o scosse elettriche.)
	<ul style="list-style-type: none"> ● Non installare la connessione di alimentazione direttamente sotto il punto di erogazione dell'acqua o lasciare che il tubo di alimentazione dell'acqua la tocchi (La presenza di condensa o simili potrebbe bagnare la connessione di alimentazione, causando incendi o scosse elettriche.)
	<ul style="list-style-type: none"> ● Non colpire, tirare, torcere, piegare eccessivamente, danneggiare, alterare o riscaldare il cavo di alimentazione, i cavi elettrici e le connessioni. Evitare inoltre di posizionare oggetti pesanti, legare o pizzicare il cavo di alimentazione, i cavi elettrici e le connessioni (L'uso di una parte danneggiata può provocare incendi, scosse elettriche, fuoriuscite di calore o cortocircuiti.)
	<ul style="list-style-type: none"> ● Non rimuovere o installare l'apparecchiatura quando l'alimentazione è accesa o durante il rifornimento d'acqua all'unità principale (In caso contrario sussiste il rischio di scossa elettrica o malfunzionamento.)
	<ul style="list-style-type: none"> ● Non installare il prodotto all'aperto, su pareti inclinate o in un luogo esposto a forti vibrazioni (L'installazione potrebbe diventare instabile e il prodotto potrebbe cadere e causare lesioni.)
 Seguire attentamente	<ul style="list-style-type: none"> ● In conformità con le leggi e gli standard della zona in cui lo si utilizza, non utilizzare altro che acqua del rubinetto o di pozzo (Ciò potrebbe causare irritazioni alla pelle e malfunzionamenti.)
	<ul style="list-style-type: none"> ● L'installazione deve rispettare gli standard locali
	<ul style="list-style-type: none"> ● Collegare sempre il prodotto all'ingresso dell'acqua fredda (In caso contrario sussiste il rischio di bruciature o malfunzionamento dell'apparecchiatura.)
 Seguire attentamente	<ul style="list-style-type: none"> ● Accertarsi di sorreggere il telaio durante il trasporto del corpo del prodotto (Se si sorregge una parte diversa, il prodotto potrebbe rompersi e causare lesioni, danni fisici o perdite d'acqua.)

 AVVERTENZA		
 Seguire attentamente	<ul style="list-style-type: none"> ● Verificare che sia installata una messa a terra appropriata ● Per la messa a terra, utilizzare cavi di rame con una resistenza di terra massima di 100 Ω e un diametro di almeno 1,6 mm (0,06 pollici) ● Se non è installata alcuna messa a terra, chiedere all'appaltatore che ha eseguito l'installazione di farlo (La mancata installazione di una messa a terra può provocare scosse elettriche in caso di malfunzionamento o perdita di corrente.)	
	<ul style="list-style-type: none"> ● Verificare che i cavi di alimentazione e quelli elettrici siano collegati correttamente ● Collegarsi a un interruttore differenziale utilizzando un dispositivo di alimentazione dotato di messa a terra ● Installare il prodotto in conformità con le restrizioni di installazione e relative ai lavori elettrici vigenti nel Paese corrispondente ● Se il cablaggio non è stato completato, chiedere all'appaltatore che ha eseguito l'installazione di farlo (In caso contrario sussiste il rischio di incendio o scosse elettriche.)	
	<ul style="list-style-type: none"> ● Installare l'apparecchiatura di alimentazione e le rispettive connessioni a una distanza di almeno 0,60 m dal bordo della doccia o della vasca da bagno (In caso contrario sussiste il rischio di incendio o scosse elettriche.)	 <p>Mehr als 0,6 m</p> <p>Installieren Sie einen Fehlerstromschutzschalter oder Trenntransformator.</p>
	<ul style="list-style-type: none"> ● Se il cavo di alimentazione è danneggiato, chiedere al reparto riparazioni del produttore o a uno specialista equivalente di sostituirlo in modo da evitare pericoli (In caso contrario sussiste il rischio di scosse elettriche.)	
 Non smontare	<ul style="list-style-type: none"> ● Verificare che i cavi siano collegati correttamente (In caso di errato collegamento dei cavi, il dispositivo potrebbe non funzionare correttamente.)	
	<ul style="list-style-type: none"> ● Si sconsiglia a persone diverse dai tecnici di smontare, riparare o alterare il prodotto (per evitare casi di malfunzionamento, scosse elettriche, o lesioni.)	

 Attenzione	
 Proibito	<ul style="list-style-type: none"> ● Non piegare o schiacciare il tubo di alimentazione dell'acqua; non danneggiare tagliando con un oggetto appuntito (Ciò potrebbe causare perdite d'acqua.)
	<ul style="list-style-type: none"> ● Non rimuovere la valvola di scarico o di riempimento mentre la valvola di intercettazione è aperta (In questo modo l'acqua fuoriesce.)
	<ul style="list-style-type: none"> ● Evitare impatti diretti con il prodotto (Altrimenti questo potrebbe rompersi e causare lesioni, danni fisici o perdite d'acqua.)
 Seguire attentamente	<ul style="list-style-type: none"> ● Eseguire il lavoro di installazione in conformità a questo manuale per l'installazione (In caso contrario, potrebbero verificarsi danni causati da perdite d'acqua.)
	<ul style="list-style-type: none"> ● Assicurarsi di utilizzare le parti incluse o specificate per il lavoro di installazione (In caso contrario, il prodotto può non essere installato correttamente.)

Included Parts / Mitgelieferte Teile / Pièces fournies / Parti incluse

Check to make sure you have all these parts from the package:

* The product may be slightly different in shape than the product shown in the figure depending on the model. /

Überprüfen Sie zunächst, ob alle Teile im Paket vorhanden sind:

* Je nach Modell kann die Form des Produkts leicht von der Abbildung abweichen. /

Assurez-vous que le kit inclut toutes ces pièces:

* La forme du produit peut être légèrement différente que celle illustrée, en fonction du modèle. /

Verificare che la confezione contenga tutte le parti indicate:

* A seconda del modello, il prodotto potrebbe avere una forma leggermente differente da quella mostrata nell'illustrazione.

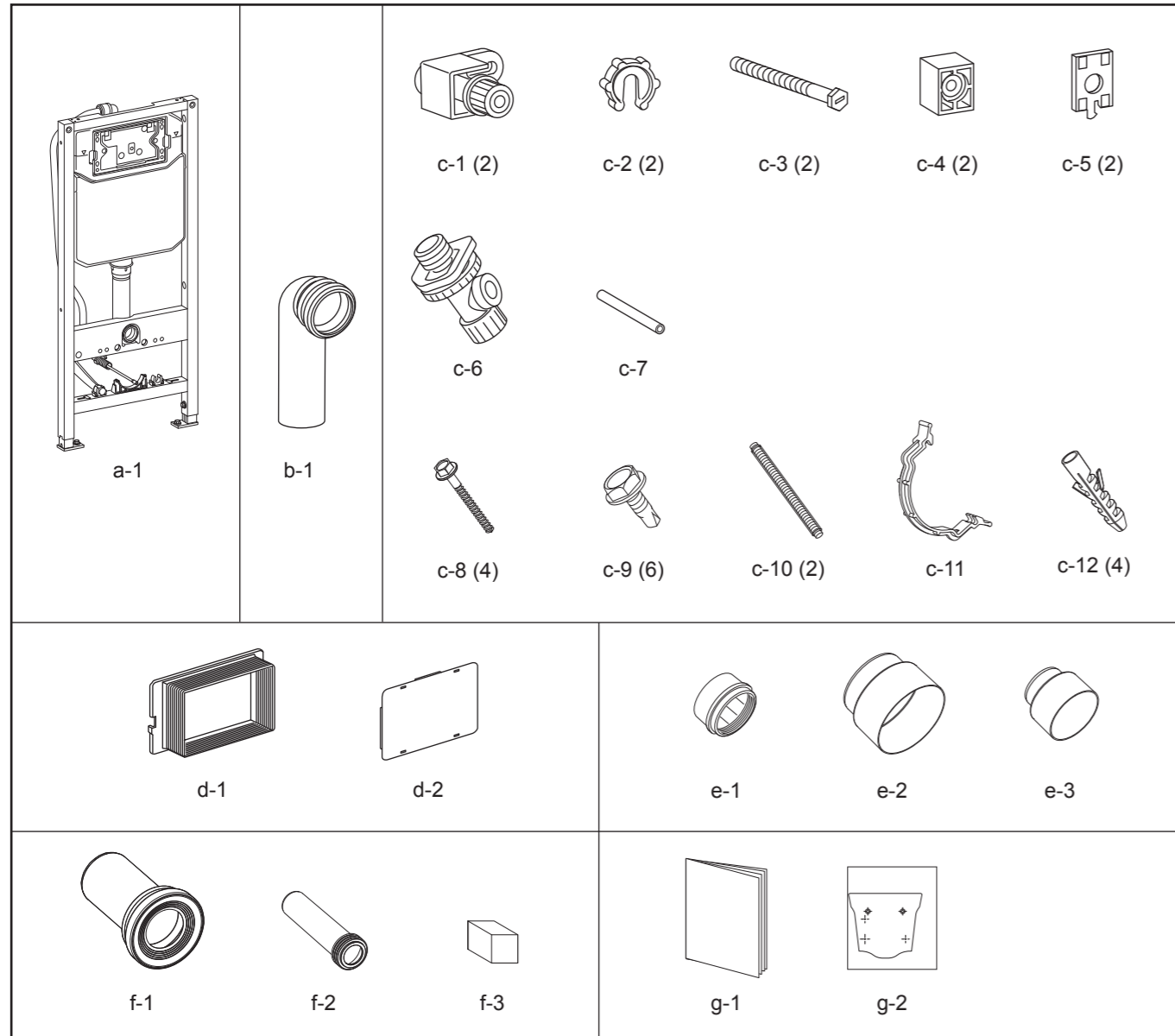

Before Installation / Vor der Installation / Avant l'installation / Prima dell'installazione

Dimensions and Supply Pipe-laying

Dimensions are based on toilet rim height 410mm /

Abmessungen und Verlegung der Zulaufleitung

Die Abmessungen beziehen sich auf eine Höhe des Toilettenrandes von 410 mm. /

Dimensions et tuyauterie d'alimentation

Les dimensions sont basées sur des rebords d'une hauteur de 410 mm /

Dimensioni e posa del tubo di fornitura

Le dimensioni si basano sull'altezza del bordo del water di 410 mm

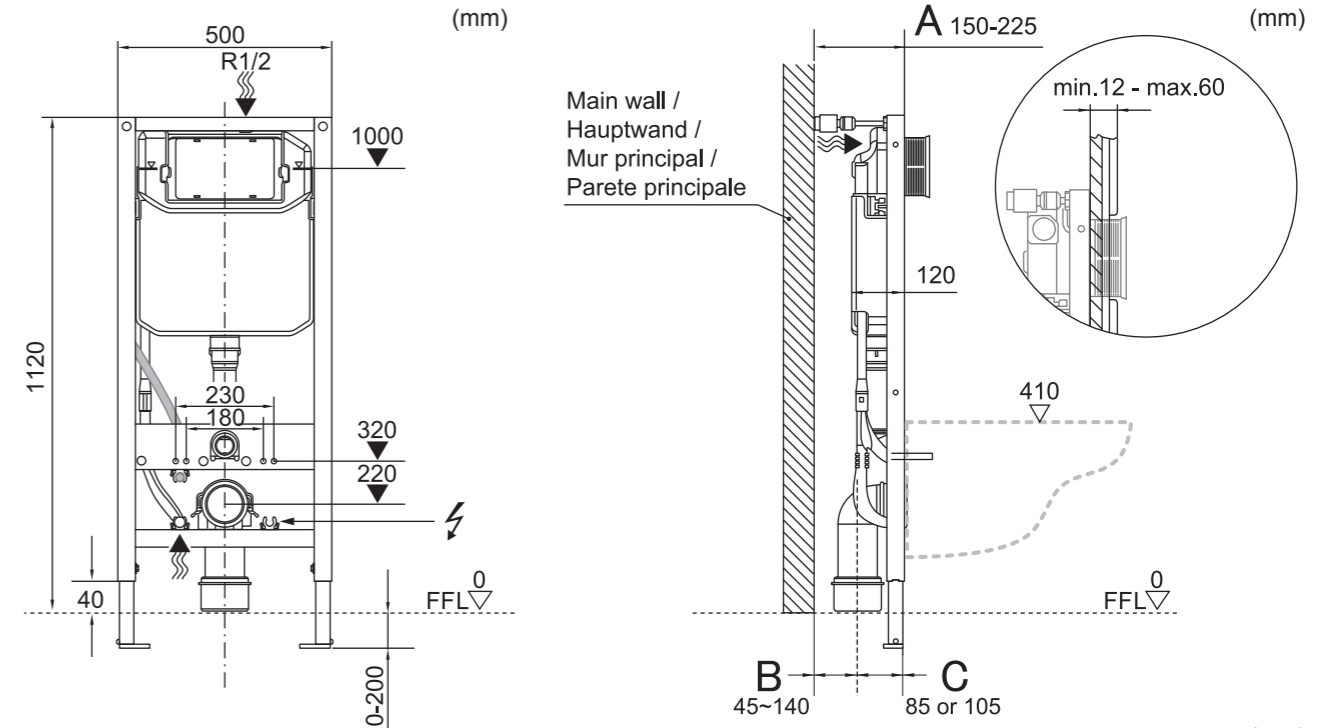

(mm)			
A	B	C	45° swing* / 45° schwingend* / Pivotement de 45** / Oscillazione di 45**
150-225	65-140	85	OK
	45-120	105	OK

Please make sure B is between 45 to 140. /

Stellen Sie bitte sicher, dass B zwischen 45 und 140 liegt. /

Assurez-vous que B est compris entre 45 et 140. /

Accertarsi che B sia compresa tra 45 e 140.

* Refer to page 17 for Installation Procedure /

* Das Installationsverfahren finden Sie auf Seite 17 /

* Reportez-vous à la page 17 pour en savoir plus sur la procédure d'installation /

* Fare riferimento a pagina 17 per la procedura di installazione

Flow of installation / Ablauf der Installation /
Processus d'installation / Procedura di installazione

Process 1-6

Installing the tank to a wall

Proceed to page 13. /

Verfahren 1-6

Installieren des Kastens an der Wand

Weiter auf Seite 13. /

Processus 1-6

Installation du réservoir au mur

Passez à la page 13. /

Passaggi 1-6

Installazione del serbatoio a una parete

Procedere alla pagina 13.

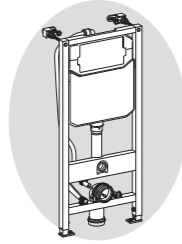

Process 1-6

Installing the tank to a frame

Proceed to page 15. /

Verfahren 1-6

Installieren des Kastens an einem Rahmen

Weiter auf Seite 15. /

Processus 1-6

Installation du réservoir sur un châssis

Passez à la page 15. /

Passaggi 1-6

Installazione del serbatoio a un telaio

Procedere alla pagina 15.

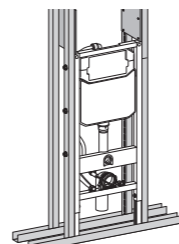

Process 7 - Process 29 /
Verfahren 7 - Verfahren 29 /
Processus 7 - Processus 29 /
Passaggi 7 - Passaggi 29

Installation procedure / Installationsverfahren /
Procédure d'installation / Procedura di installazione

Symbols and their meanings / Symbole und deren Bedeutung / Symboles et significations /

Simboli e relativo significato



: Visual confirmation required. /
Visuelle Bestätigung erforderlich. /
Une confirmation visuelle est nécessaire. /
Necessaria conferma visiva.



: Check that a sound was made. /
Überprüfen Sie, ob ein Geräusch zu hören ist. /
Vérifiez l'émission d'un son. /
Verificare che sia stato emesso un suono.

Installation procedure / Installationsverfahren /
Procédure d'installation / Procedura di installazione



I

A

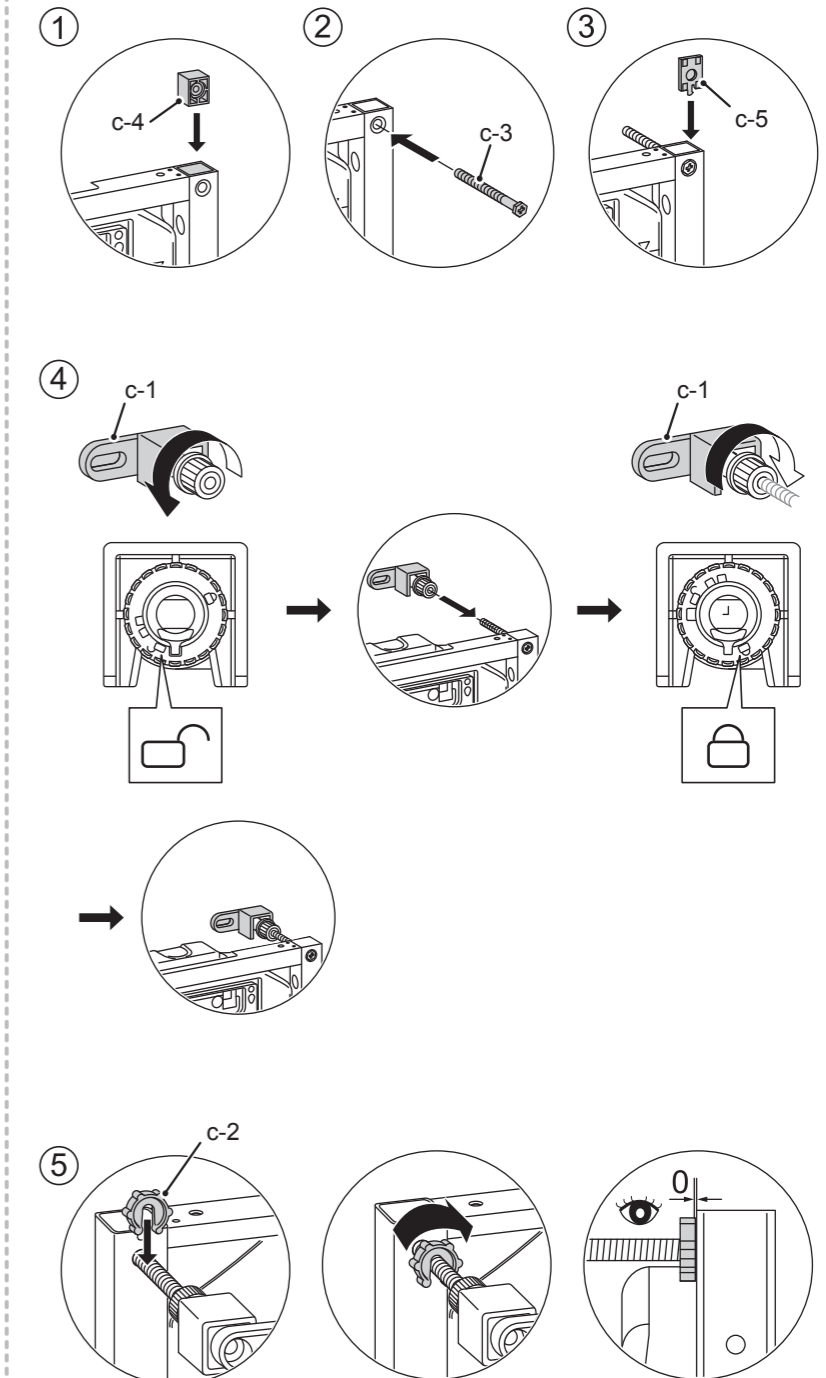
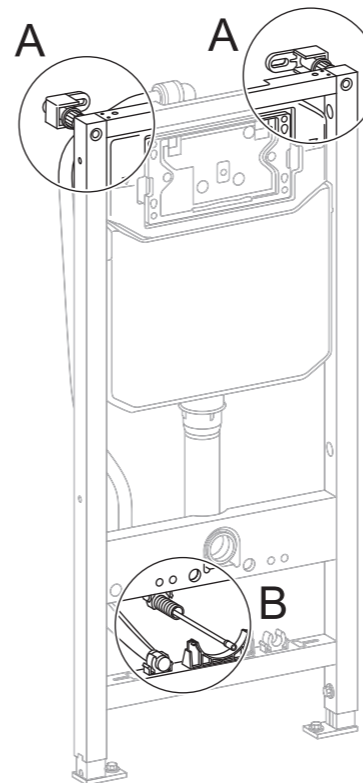

B

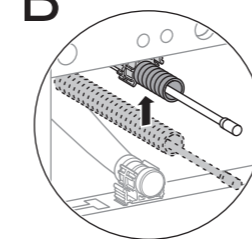

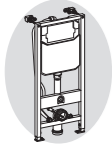

2

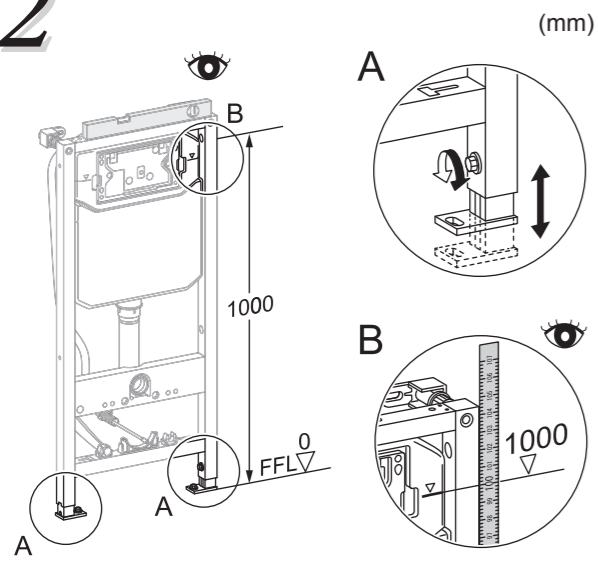

5

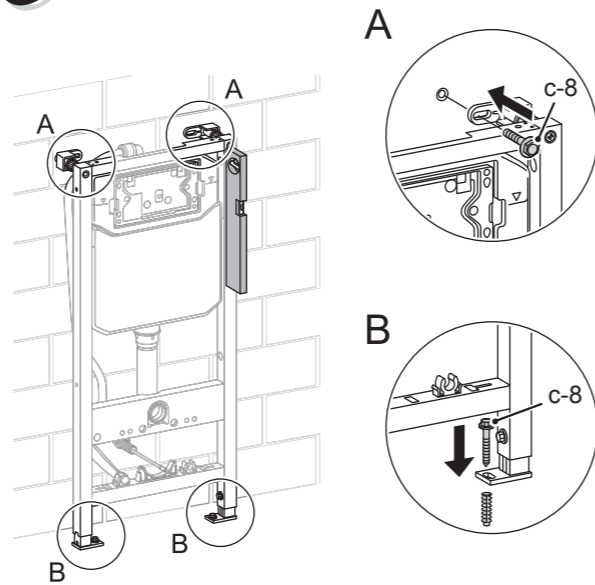

3

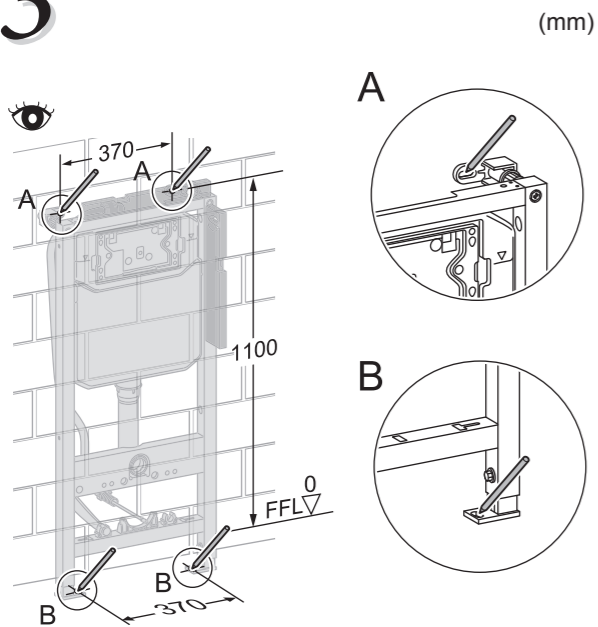

6

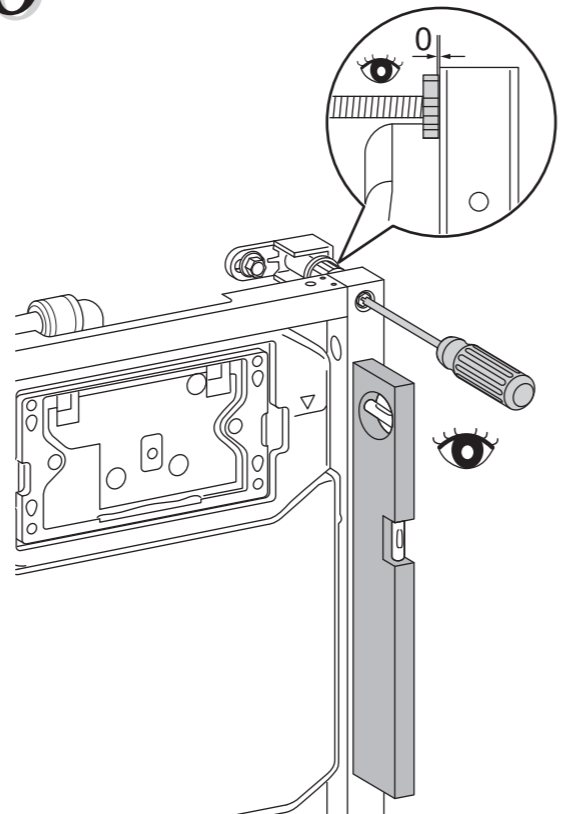

4

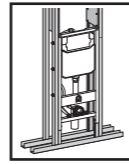
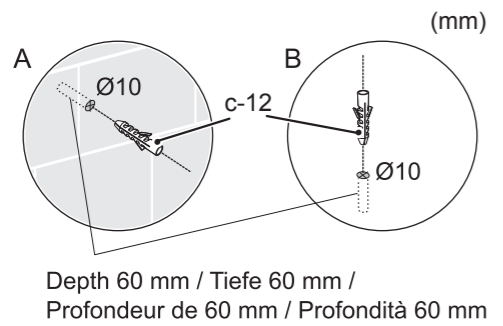

1

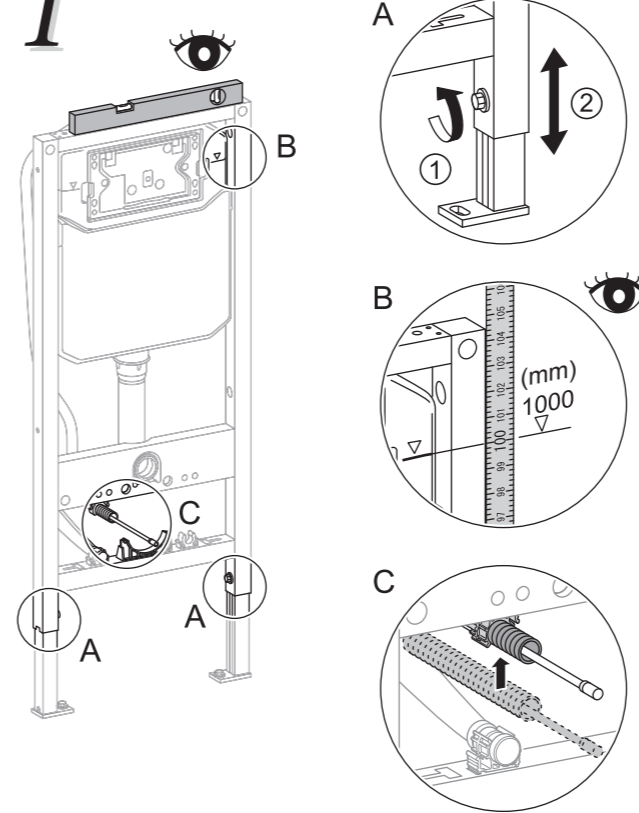

4

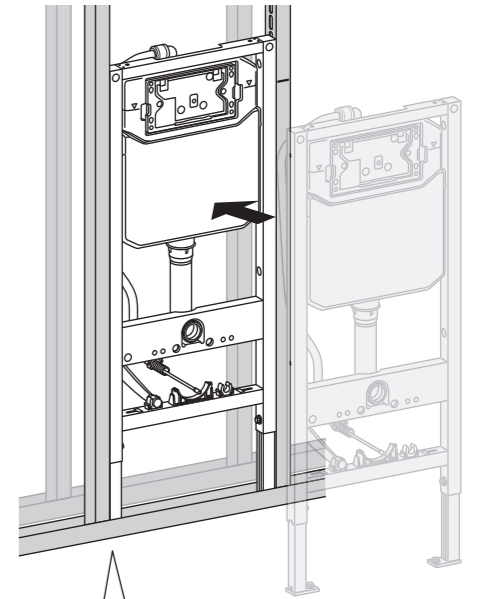

2

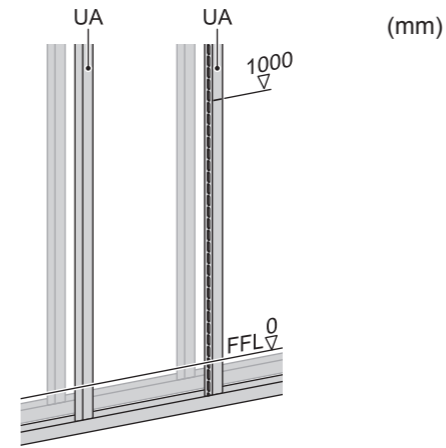

3

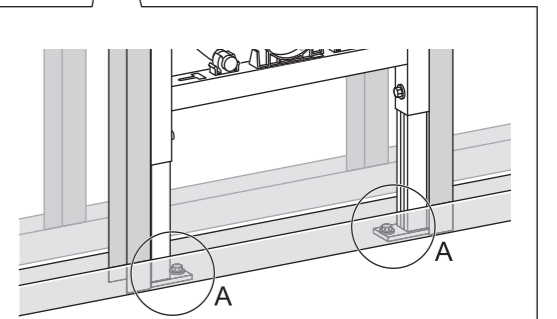
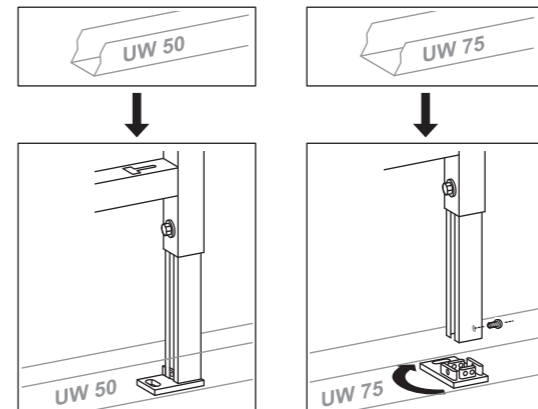

A

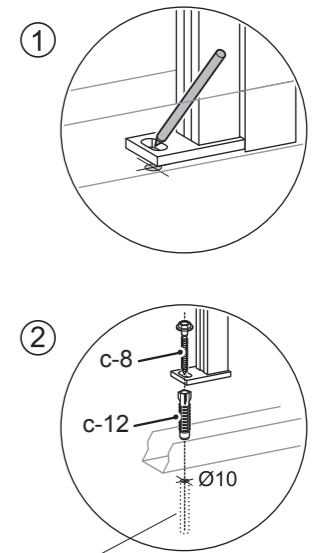

Depth 60 mm / Tiefe 60 mm /
Profondeur de 60 mm / Profondità 60 mm

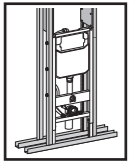

5

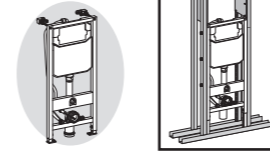
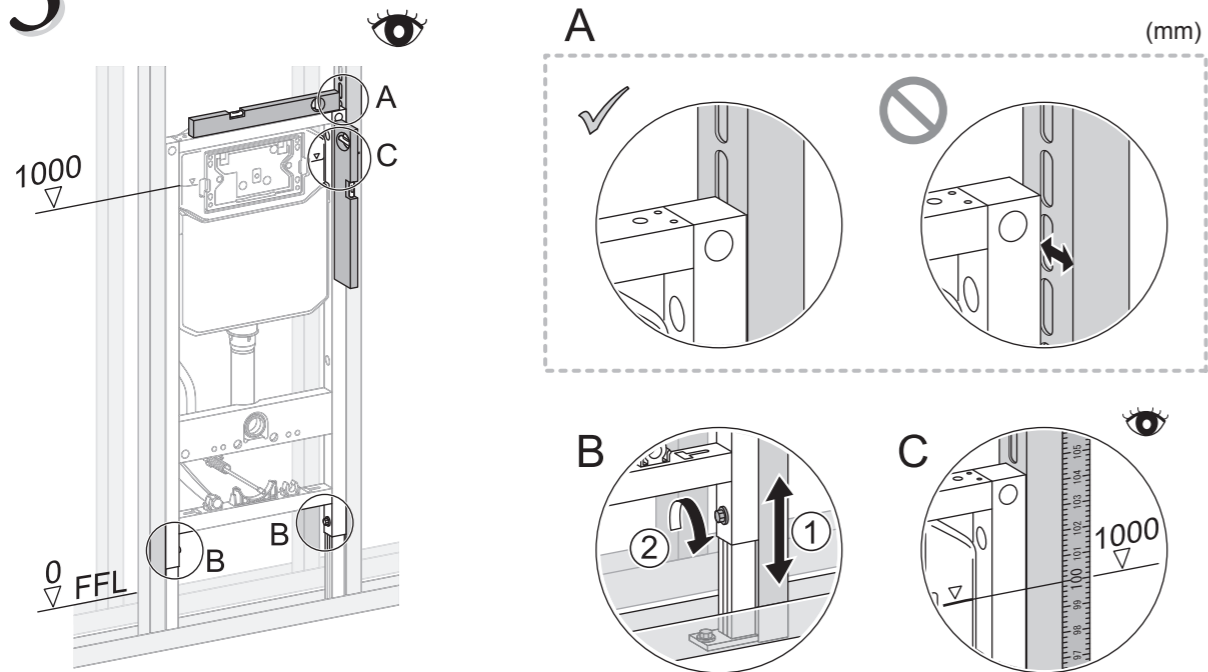

7

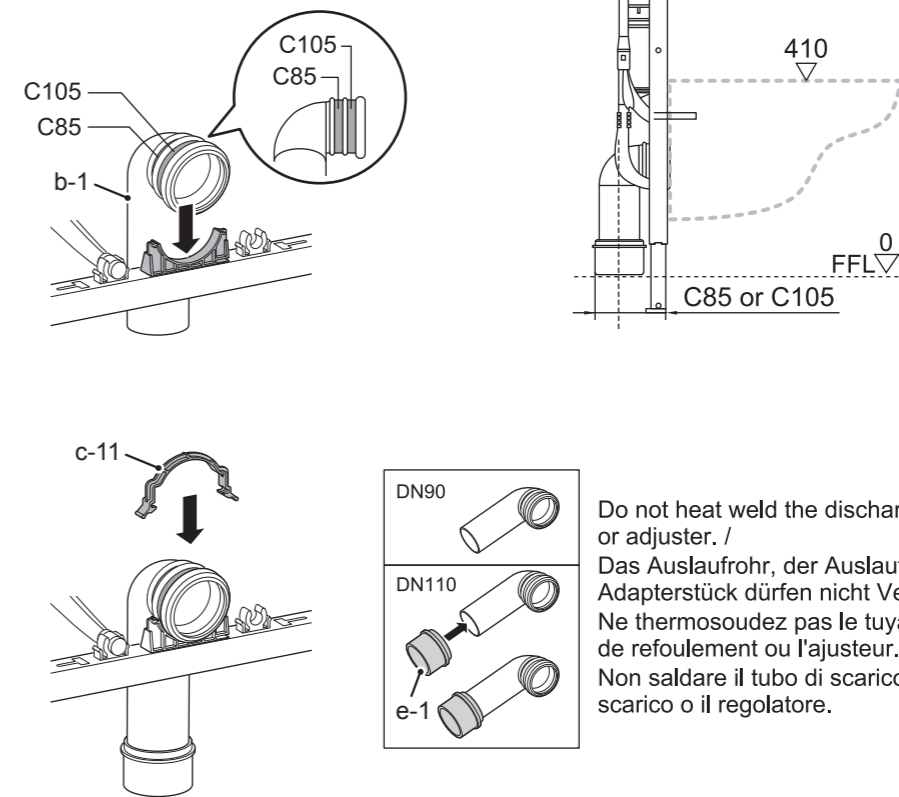

Do not heat weld the discharge pipe, discharge elbow, or adjuster. /
Das Auslaufrohr, der Auslaufbogen oder das Adapterstück dürfen nicht Verschweißt werden. /
Ne thermosoudez pas le tuyau d'évacuation, le coude de refoulement ou l'ajusteur. /
Non saldare il tubo di scarico, il raccordo a gomito di scarico o il regolatore.

6

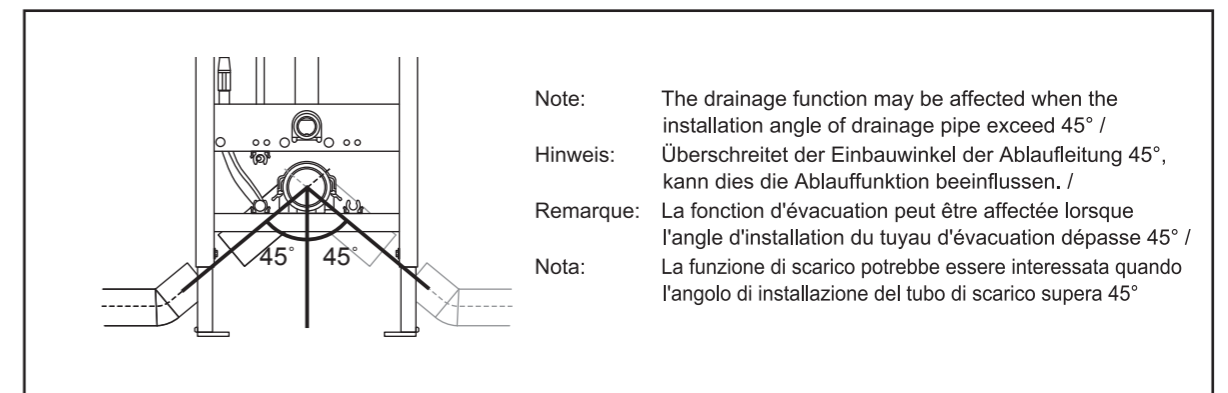
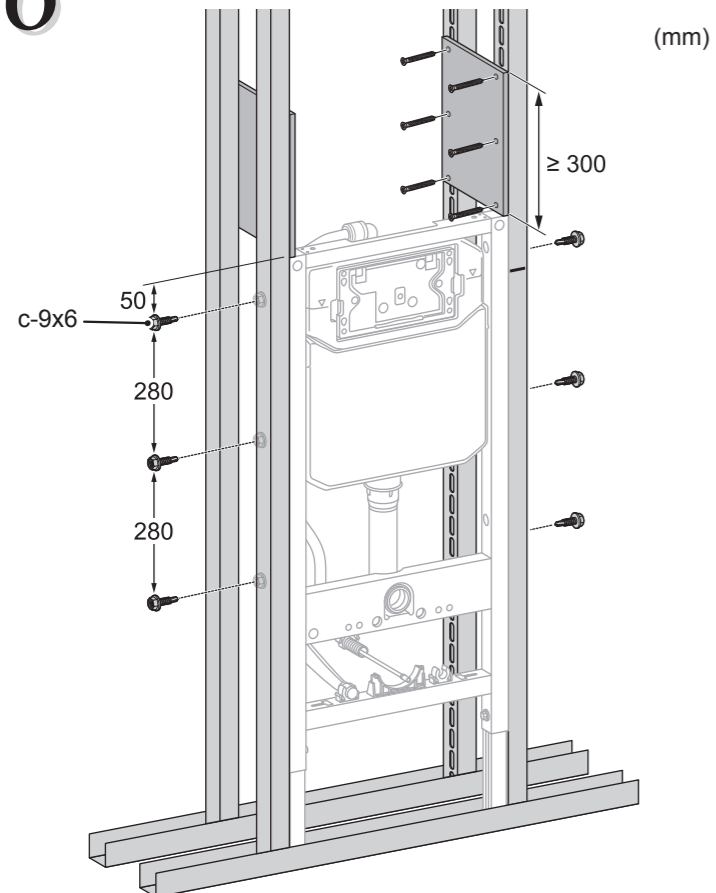

Note: The drainage function may be affected when the installation angle of drainage pipe exceed 45° /
Hinweis: Überschreitet der Einbauwinkel der Ablaufleitung 45°, kann dies die Ablauffunktion beeinflussen. /
Remarque: La fonction d'évacuation peut être affectée lorsque l'angle d'installation du tuyau d'évacuation dépasse 45° /
Nota: La funzione di scarico potrebbe essere interessata quando l'angolo di installazione del tubo di scarico supera 45°

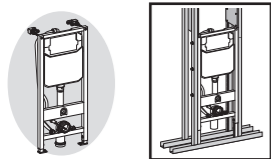

8

8.1

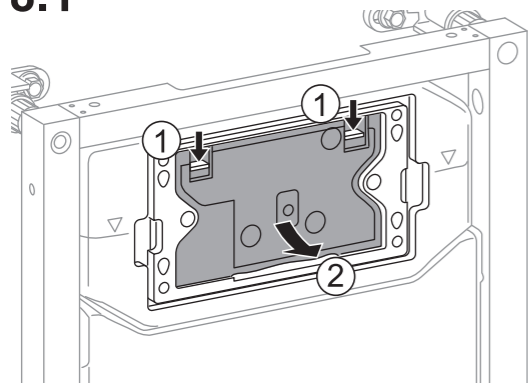

8.2

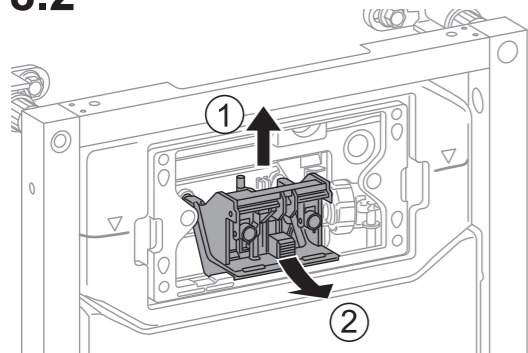

8.3

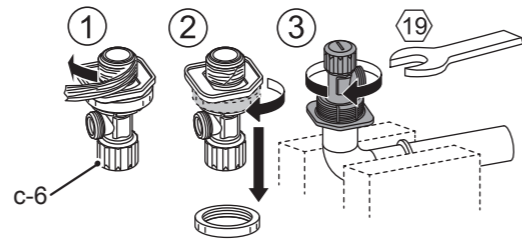

8.4

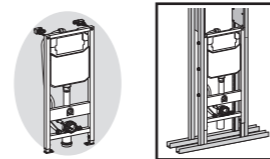
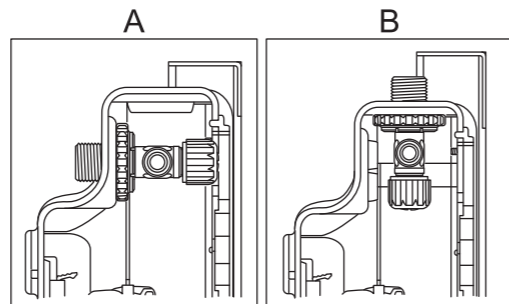
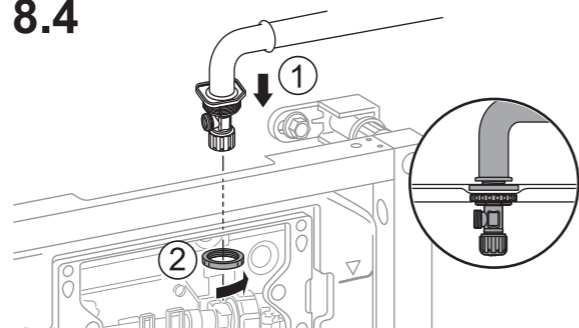

8

8.5

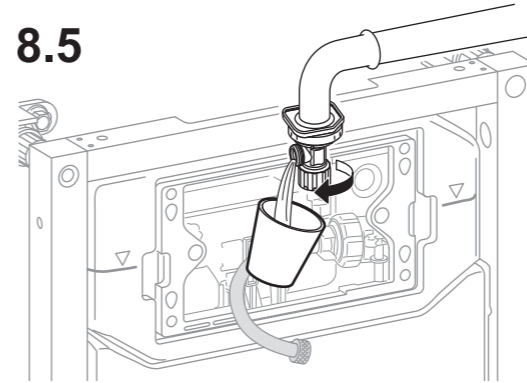

8.6

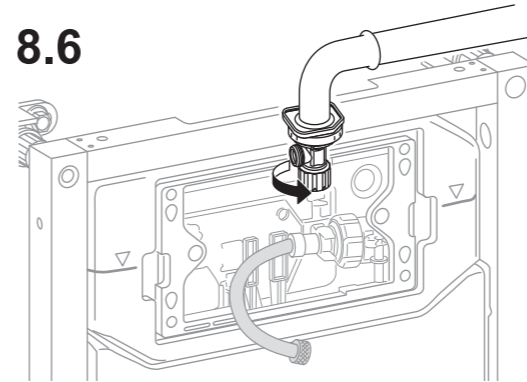

8.7

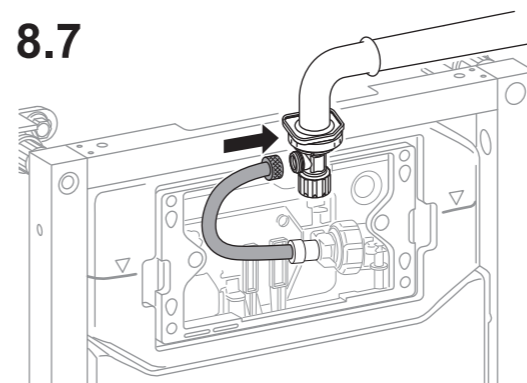

8.8

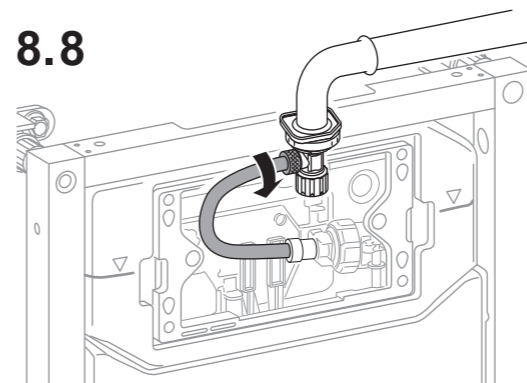

EN	⚠ CAUTION
This indicates that misoperation could result in injury or physical damage.	
! Required	It is important to reconfirm that there is no water leakage at all connections. Incomplete connection could cause foul odor or water to leak.

The **!** symbol indicates something that must be done.

DE	⚠ VORSICHT
Dies weist darauf hin, dass eine falsche Bedienung zu körperlichen Verletzungen oder Sachschäden führen kann.	
! Zwingend erforderlich	Es ist notwendig, sich erneut zu vergewissern, dass es keine Wasserlecks an den Anschlüssen gibt. Eine unvollständige Verbindung kann zu üblen Gerüchen und Wasserlecks führen.

Mit **!** werden unbedingt auszuführende Arbeitsinhalte gekennzeichnet.

FR	⚠ MISE EN GARDE
Ce symbole indique que toute utilisation incorrecte peut entraîner des blessures ou des dommages matériels.	
! Obligatoire	Il est important de reconfirmer l'absence de fuite d'eau au niveau de tous les raccords. Un raccord incomplet peut entraîner de mauvaises odeurs ou une fuite d'eau.

Le symbole **!** indique qu'une intervention est requise.

IT	⚠ ATTENZIONE
Questo indica che un'operazione errata può avere come conseguenza lesioni o danni fisici.	
! Richiesto	È importante riconfermare l'assenza di perdite d'acqua in tutte le connessioni. Una connessione incompleta potrebbe causare la fuoriuscita di cattivo odore o acqua.

Il simbolo **!** a sinistra indica un'operazione che è necessario eseguire.

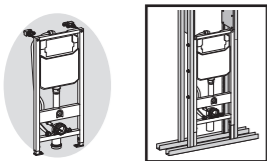

9

9.1

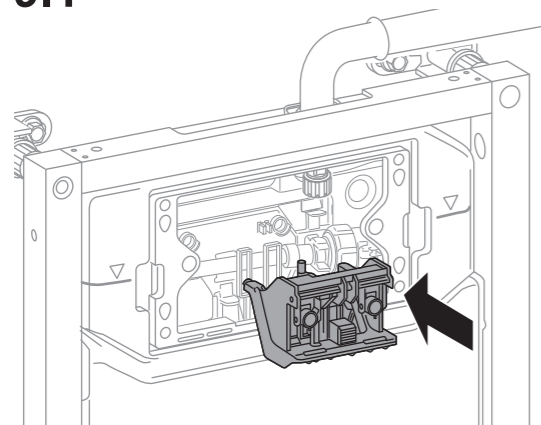

9.3

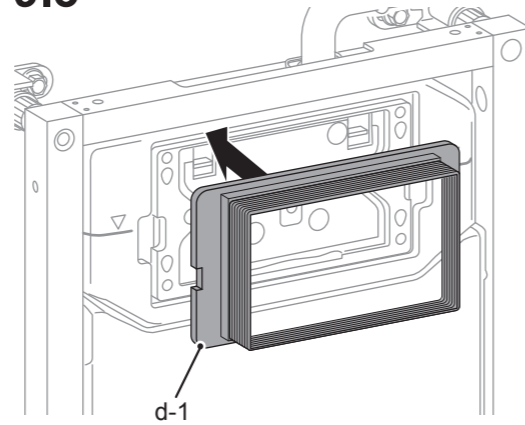

9.2

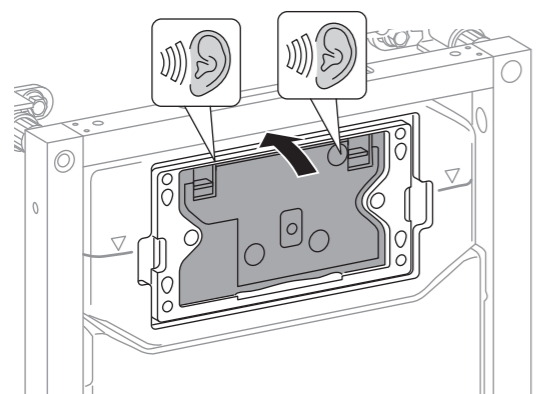

9.4

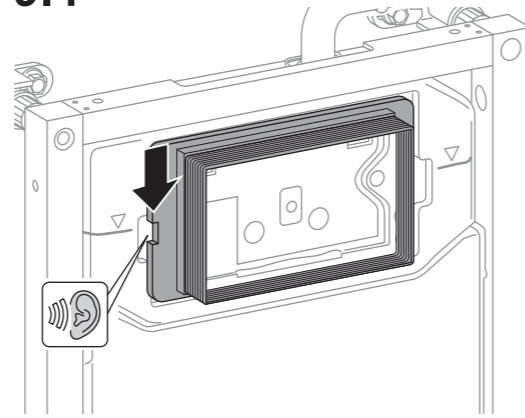

10

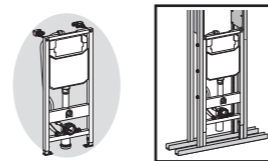
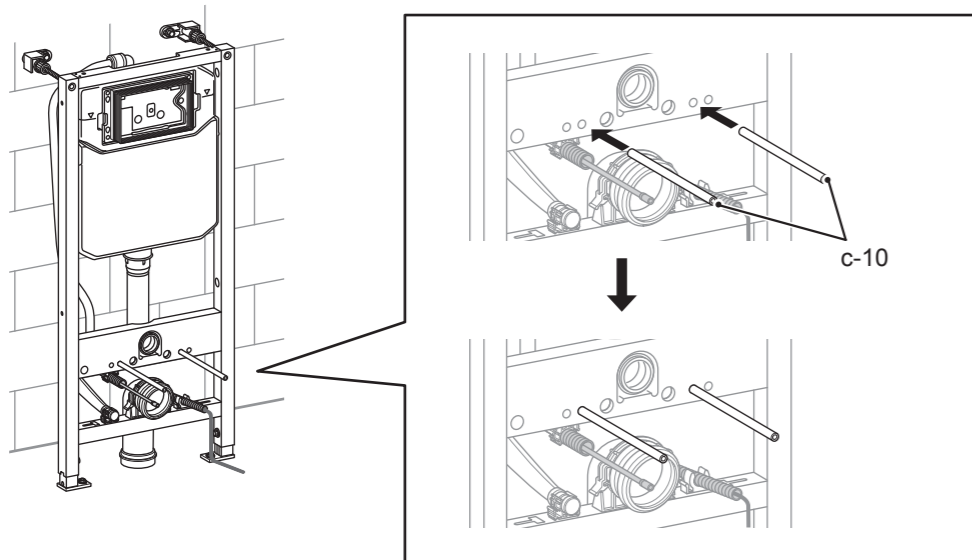

11

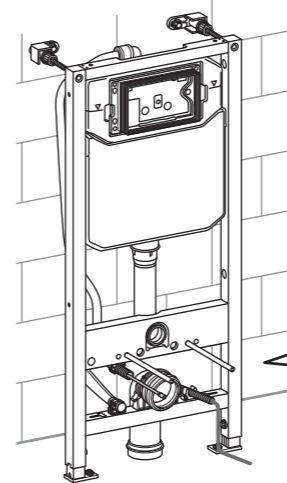

+10 mm the wall thickness / + 10 mm Wanddicke /
à 10 mm du mur / +10 mm spessore della parete

It must be arranged separately. /
Sie müssen getrennt voneinander
eingestellt werden. /
Il faut en prévoir par ailleurs. /
Disporre separatamente. /

Power Supply Cord / Stromkabel /
Cordon d'alimentation électrique /
Cavo di alimentazione elettrica

NOTICE: Do not remove the protective tube. /
ANMERKUNG: Nicht das Schutzrohr entfernen. /
REMARQUE: Ne retirez pas le tube protecteur. /
NOTA: non rimuovere il tubo protettivo.

12

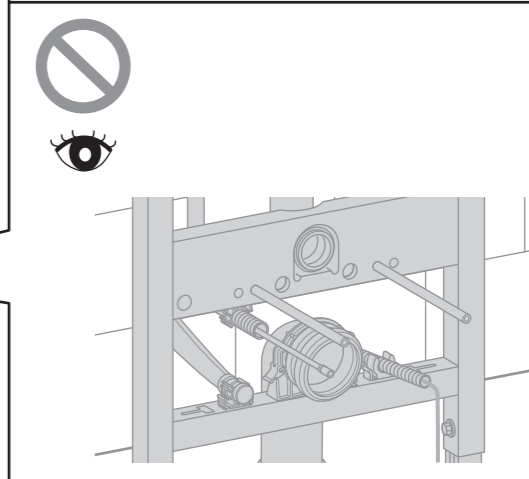
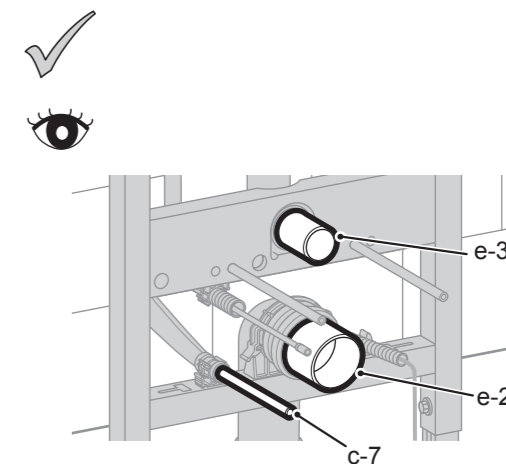
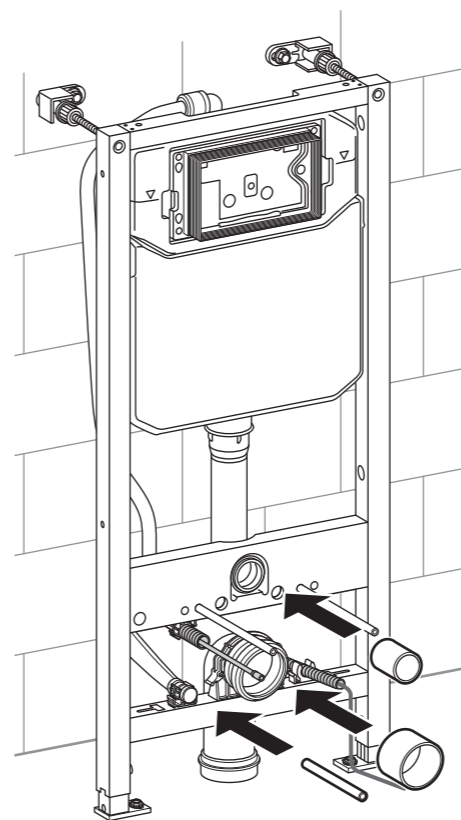

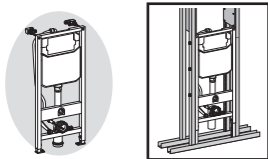

13

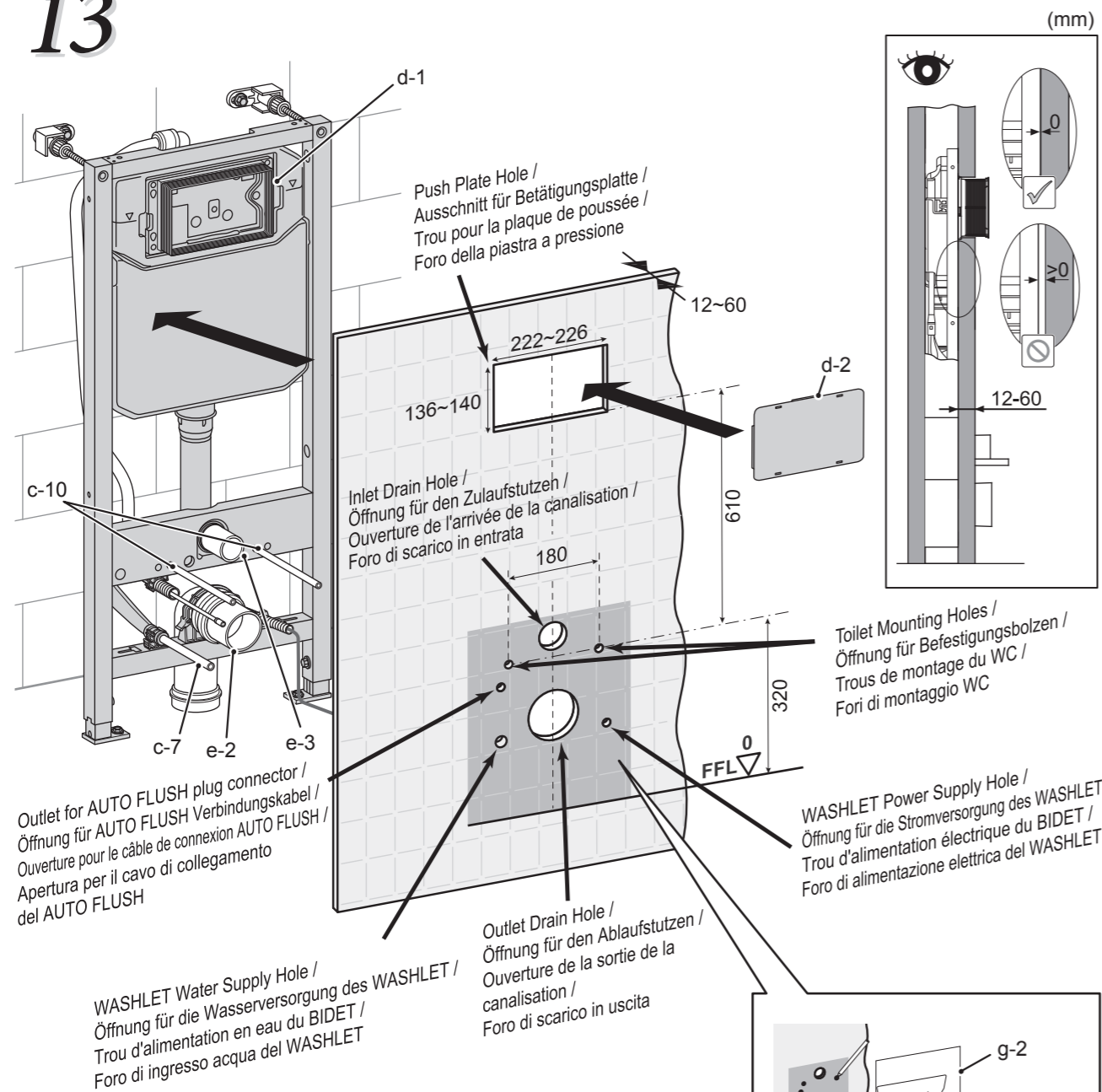

- ⚠ It is forbidden to use unsustainable, ductile or light-weight material to fix the covering. Such as foam board etc. /
- ⚠ Es ist verboten, instabile, verformbare oder leichte Materialien für die Abdeckung zu verwenden. Wie z. B. Styroporplatten /
- ⚠ Il est interdit d'utiliser un matériau non durable, ductile ou léger pour fixer le revêtement, comme une plaque de mousse, etc. /
- ⚠ È vietato utilizzare materiali non sostenibili, duttili o di peso leggero per fissare la copertura. Ad esempio, pannello in schiuma e così via.

Refer to 23 page for more detail dimensions. /
 Genauere Abmessungen finden Sie auf Seite 23. /
 Reportez-vous à la page 23 pour plus de détails concernant les dimensions. /
 Fare riferimento a pagina 23 per ulteriori dimensioni dettagliate.

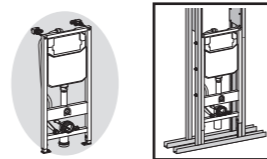

13

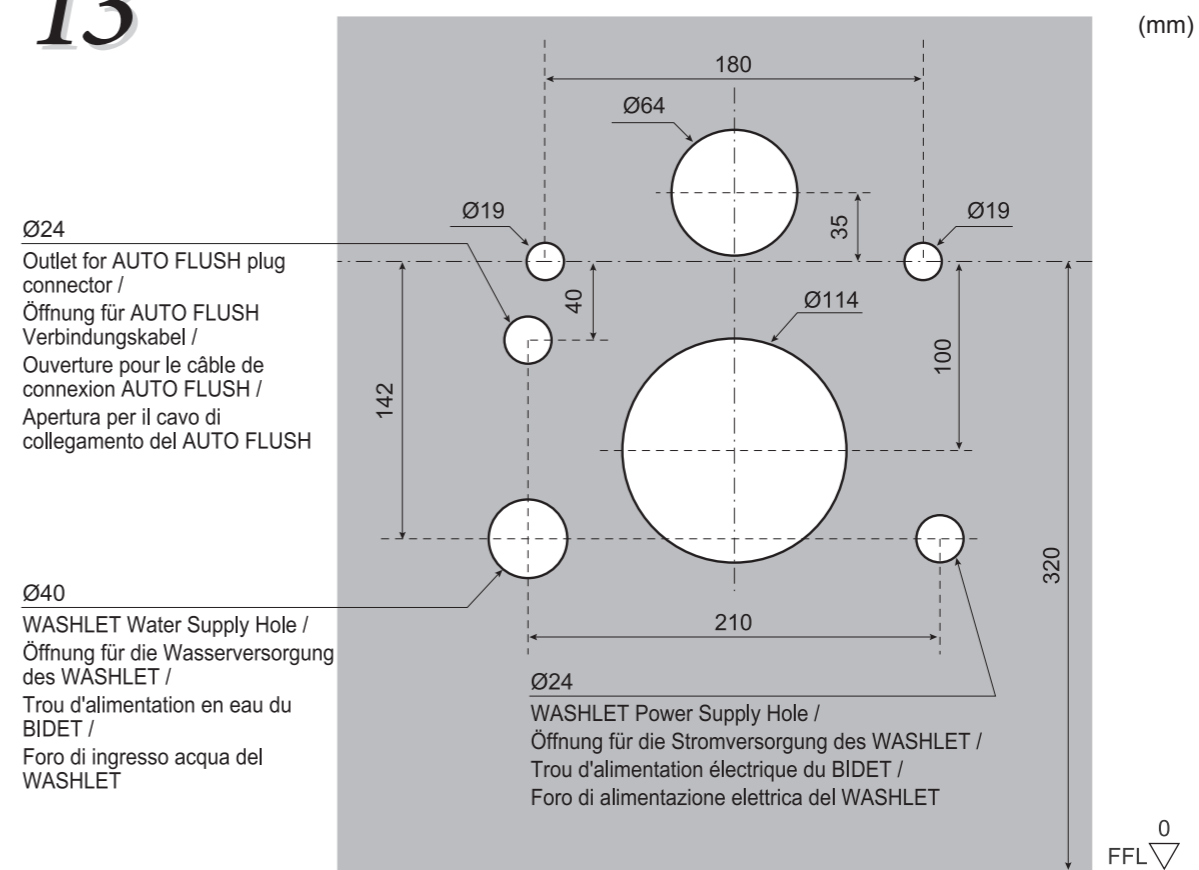

14

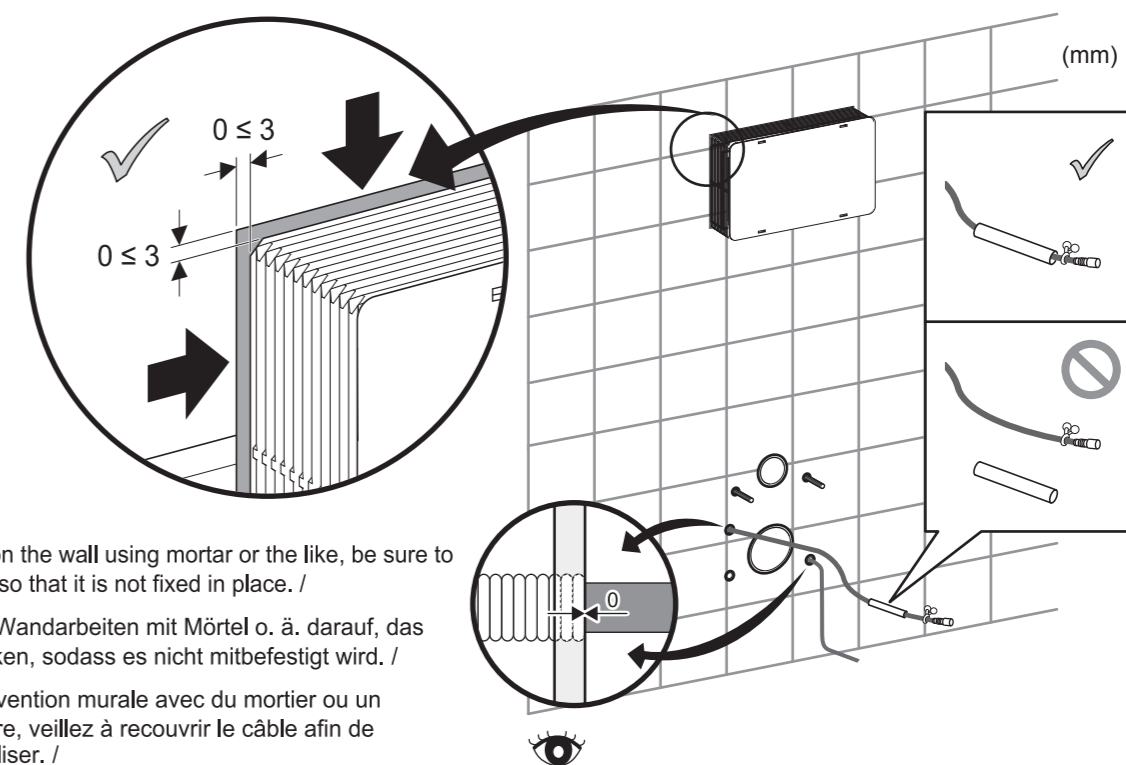

- When working on the wall using mortar or the like, be sure to cover the cable so that it is not fixed in place. /
 Achten Sie bei Wandarbeiten mit Mörtel o. ä. darauf, das Kabel abzudecken, sodass es nicht mitbefestigt wird. /
 Lors d'une intervention murale avec du mortier ou un matériau similaire, veillez à recouvrir le câble afin de ne pas l'immobiliser. /
 Nell'applicare la malta o materiali simili alla parete, accertarsi di coprire il cavo in modo che non sia fissato in posizione.

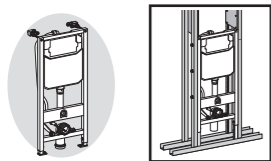

15

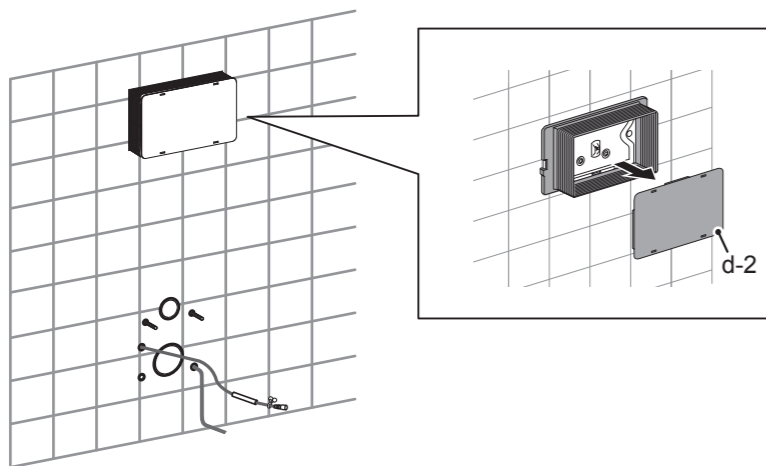

16

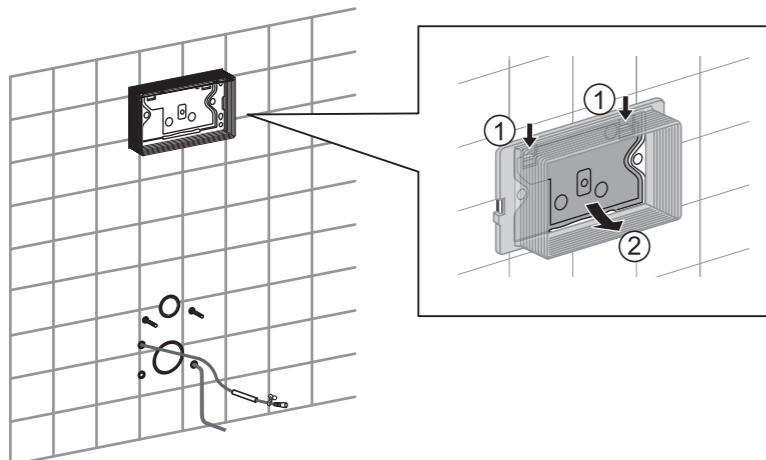

17

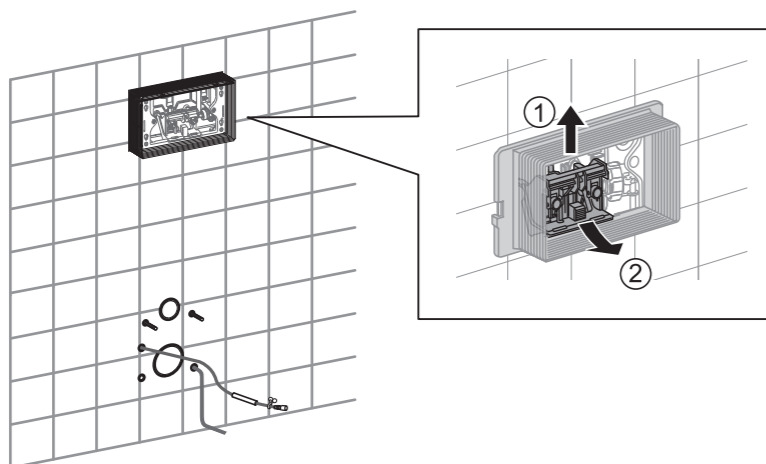

18

Install the Connecting set (refer to the Installation Guide for the Connecting set) /
 Installieren Sie das Anschlussset (siehe entsprechende Installationsanleitung). /
 Installez Kit de raccordement (reportez-vous au guide d'installation pour en savoir plus sur Kit de raccordement) /
 Installare il Kit di allaccio (fare riferimento alla Guida di installazione in merito)

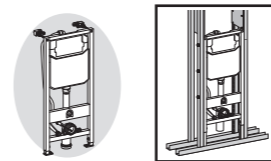

19

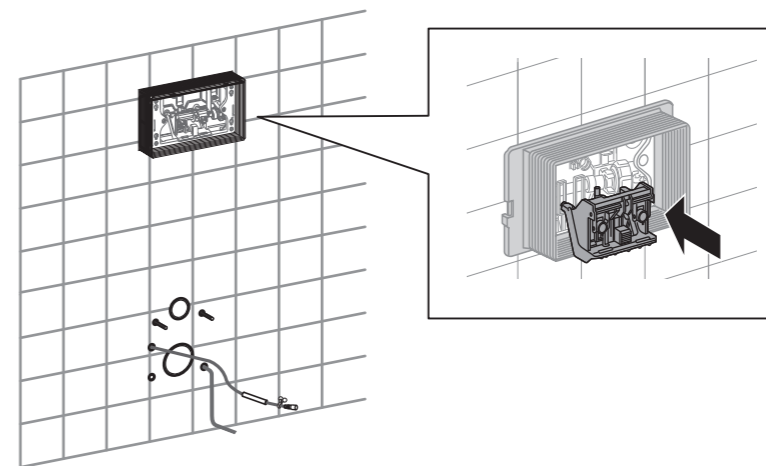

20

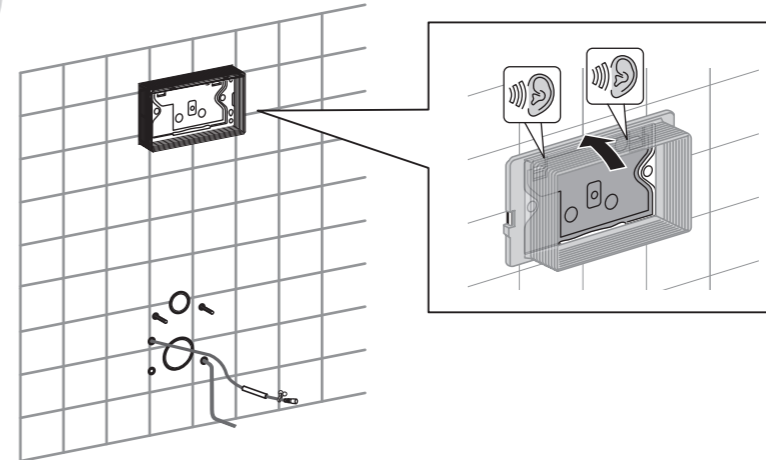

21

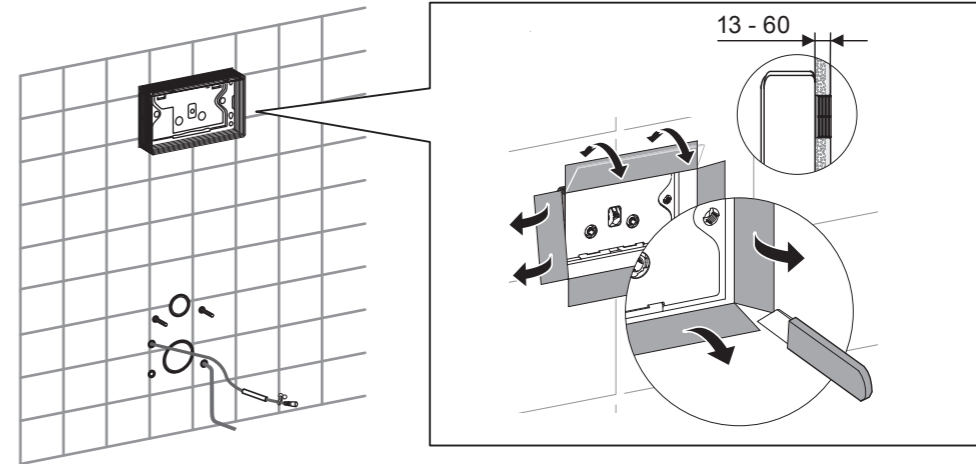

(mm)

If the cut protective cover protrudes out of the wall, it could mean that the push plate has not been installed correctly which can cause potential damage and injuries. /

Wenn die Schutzabdeckung aus der Wand herausragt, wurde die Betätigungsplatte möglicherweise nicht korrekt installiert. Dies kann zu Schäden und Verletzungen führen. /

Si le cache de protection découpé dépasse du mur, cela peut signifier que la plaque de poussée n'a pas été installée correctement, ce qui peut causer de potentiels dommages et blessures. /

Se il coperchio protettivo sporge dalla parete significa che la piastra di spinta non è installata correttamente; ciò può causare potenziali danni e lesioni.

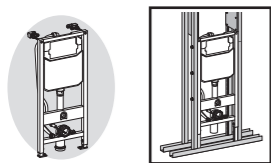

22

Refer to the Installation Guide enclosed with the push plate for information on how to install it. /
 Bitte lesen Sie für Informationen zur Installation in der Installationsanleitung nach, die im Lieferumfang der Betätigungsplatte enthalten ist. /
 Reportez-vous au guide d'installation fourni avec plaque de poussée pour plus d'informations sur son installation. /
 Per informazioni sulle modalità di installazione consultare la Guida per l'installazione in dotazione con la piastra a pressione.

23

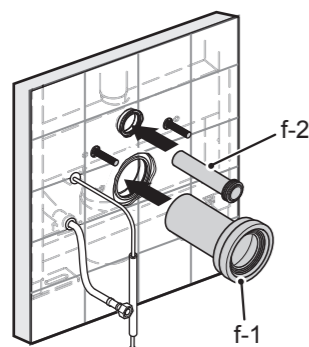

24

Set the pipes straight into the flush bend and drain bend and mark them accordingly. /
 Setzen Sie die Leitungen gerade in den Spülbogen und den Abflussbogen und markieren Sie sie entsprechend. /
 Raccordez directement les tuyaux au coude de vidange et au coude d'écoulement et marquez leurs emplacements respectifs. /
 Montare direttamente i rispettivi tubi nella piegatura dello sciacquone e in quella di scarico.

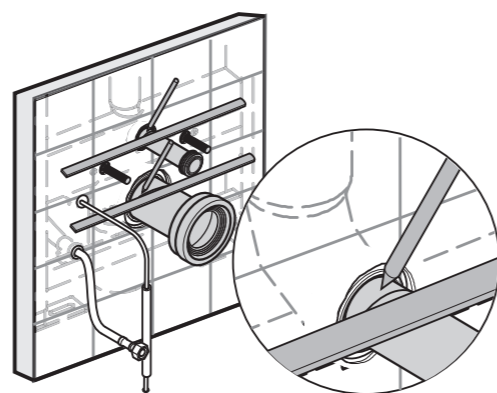

25

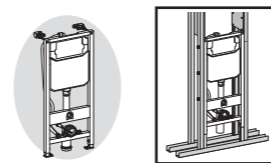
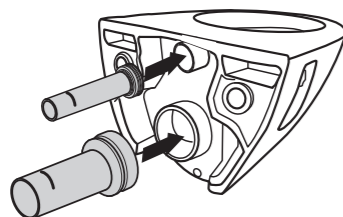

26

Mark lines as shows. /
 Wie gezeigt markieren. /
 Marquez les lignes comme illustré. /
 Contrassegnare le linee come illustrato.

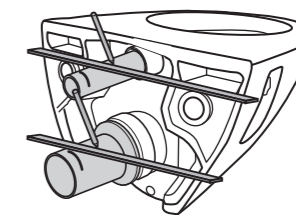

27

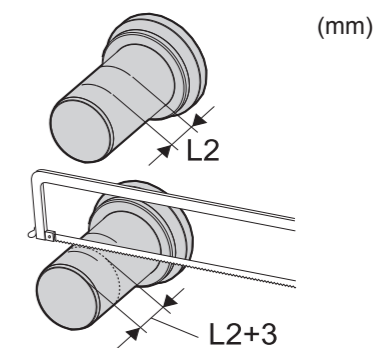
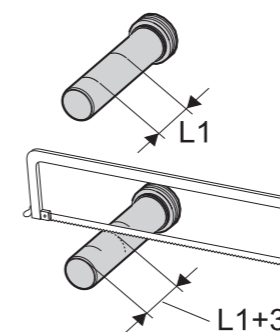

28

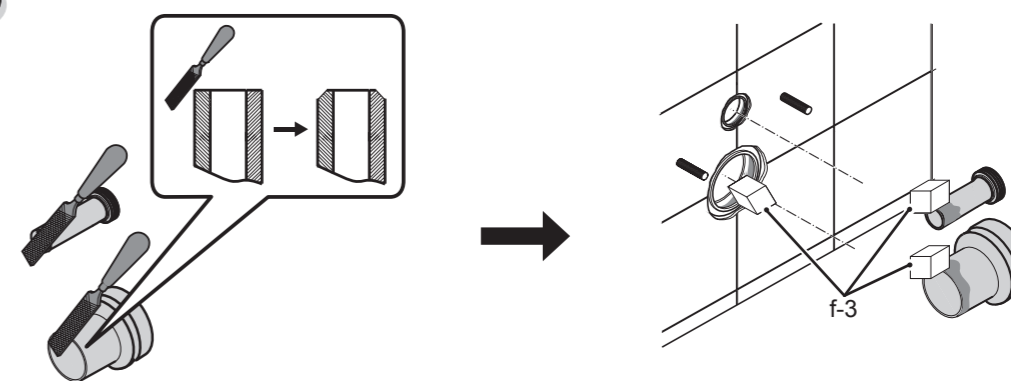

29

Refer to the Installation Guide enclosed with the toilet bowl for information on how to install it. /
 Bitte lesen Sie für Informationen zur Installation in der Installationsanleitung nach, die im Lieferumfang der Toilettenschüssel enthalten ist. /
 Reportez-vous au guide d'installation fourni avec la cuvette de toilettes pour plus d'informations sur son installation. /
 Per informazioni sulle modalità di installazione consultare la Guida per l'installazione in dotazione con il water.

**Servicing procedures / Wartungsverfahren /
Procédures de réparation / Procedure di manutenzione**

Servicing and / or Replacing the Flush Valve, Replacing the Auto Flush Unit /
Wartung und/oder Austausch des Spülventils, Austausch der automatischen Spüleinheit /
Réparer et/ou remplacer le robinet de la chasse d'eau, Remplacer l'unité d'actionnement automatique de la chasse d'eau /
Manutenzione e/o sostituzione della valvola di scarico, sostituzione dello sciacquone automatico

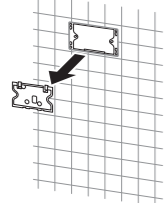
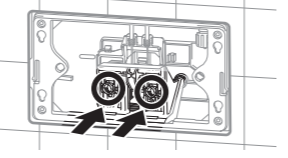
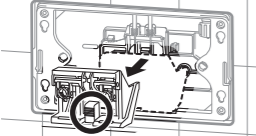
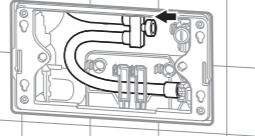
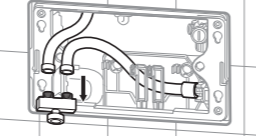
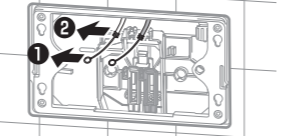
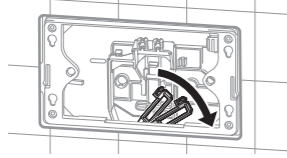
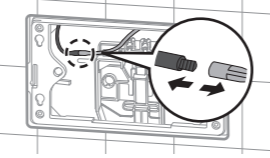
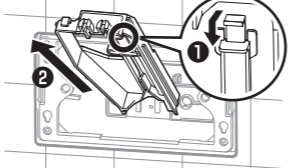
<p>1.</p> 	<p>2.</p> <p>Close the shutoff valve in the tank, and then push the button on the actuator to flush the water. / Schließen Sie das Absperrventil im Kasten und drücken Sie dann den Knopf an der Betätigungsplatte, um zu spülen. / Fermez la vanne d'eau dans le réservoir et appuyez sur le bouton du déclencheur pour actionner la chasse d'eau. / Chiudere la valvola di chiusura nel serbatoio e premere il pulsante sull'attuatore per azionare lo sciacquone del water.</p> 	
<p>3.</p> 	<p>4.</p> 	<p>5.</p> 
<p>6.</p> <p>Disconnect the cable from the flush valve and wire tube from the hold-down bracket. / Lösen Sie das Kabel vom Spülventil und das Kabelrohr von der Halterung. / Déconnectez le câble du robinet de la chasse d'eau et le tube du câble du cadre de maintien. / Scollegare il cavo dalla valvola di scarico e la canalina dei cavi dal supporto premuto.</p> 		
<p>7.</p> 	<p>8.</p> 	
<p>9.</p> <p>Remove the hold-down bracket by pulling on the tab indicated. / Entfernen Sie die Halterung, indem Sie an der gezeigten Lasche ziehen. / Retirez le cadre de maintien en appuyant sur la languette indiquée. / Rimuovere il supporto di abbassamento tirando sulla linguetta indicata.</p> 		

**Servicing procedures / Wartungsverfahren /
Procédures de réparation / Procedure di manutenzione**

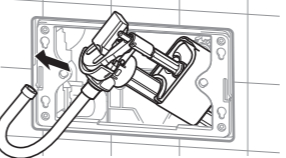
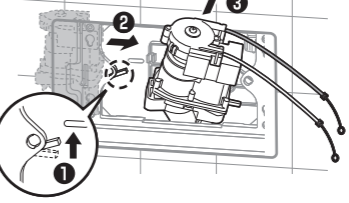
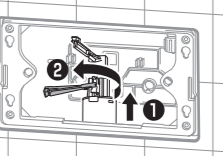
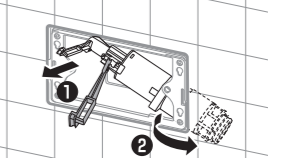
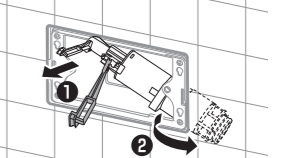
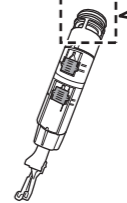
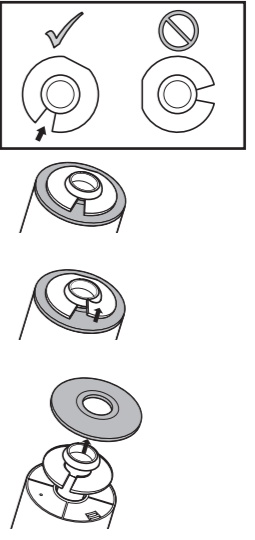
<p>10.</p> 	<p>11.</p> 	<p>12.</p> 
<p>13.</p> <p>Rotate the whole unit as you pull it out. / Ziehen Sie die ganze Einheit unter gleichzeitigem Drehen heraus. / Tournez l'ensemble de l'unité en la sortant. / Ruotare l'intera unità mentre la si estrae.</p> 		
<p>14.</p> <p>At the other end of the flush valve, the rubber piece can be removed for cleaning or to be replaced. / Das Gummistück am anderen Ende des Spülventils kann zur Reinigung oder zum Austausch entfernt werden. / À l'autre extrémité du robinet de la chasse d'eau, la pièce en caoutchouc peut être retirée pour être nettoyée ou remplacée. / All'altra estremità della valvola di scarico, è possibile rimuovere il pezzo di gomma per pulirlo o sostituirlo.</p>  <div data-bbox="2448 808 2760 1344" style="border: 1px solid black; padding: 5px;"> <p>1</p>  </div>		
<p>15.</p> <p>To install the parts back into the tank, do the reverse order. / Um die Teile wieder im Kasten anzubringen, gehen Sie in umgekehrter Reihenfolge vor. / Procédez dans l'ordre inverse pour réinstaller les pièces sur le réservoir. / Per installare di nuovo le parti nel serbatoio, ripetere la procedura inversa.</p>		

Cleaning the Filter of the Fill Valve / Reinigung des Füllventilfilters /
Nettoyage du filtre de la vanne de remplissage / Pulizia del filtro della valvola di riempimento

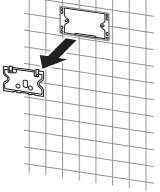
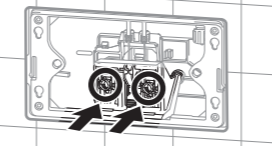
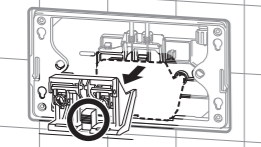
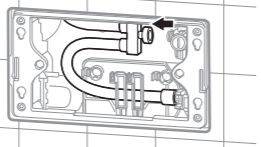
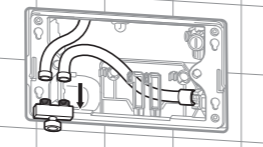
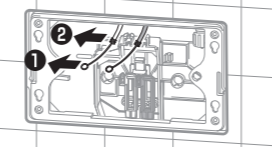
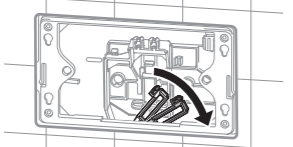
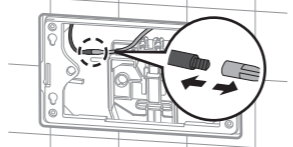
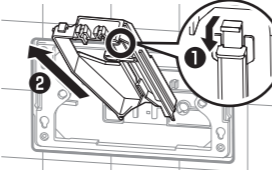
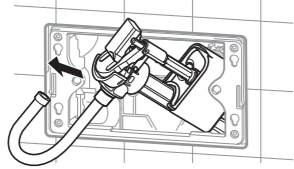
<p>1.</p> 	<p>2. Close the shutoff valve in the tank, and then push the button on the actuator to flush the water. / Schließen Sie das Absperrventil im Kasten und drücken Sie dann den Knopf an der Betätigungsplatte, um zu spülen. / Fermez la vanne d'eau dans le réservoir et appuyez sur le bouton du déclencheur pour actionner la chasse d'eau. / Chiudere la valvola di chiusura nel serbatoio e premere il pulsante sull'attuatore per azionare lo sciacquone del water.</p> 	
<p>3.</p> 	<p>4.</p> 	<p>5.</p> 
<p>6. Disconnect the cable from the flush valve and wire tube from the hold-down bracket. / Lösen Sie das Kabel vom Spülventil und das Kabelrohr von der Halterung. / Déconnectez le câble du robinet de la chasse d'eau et le tube du câble du cadre de maintien. / Scollegare il cavo dalla valvola di scarico e la canalina dei cavi dal supporto premuto.</p> 		
<p>7.</p> 	<p>8.</p> 	
<p>9. Remove the hold-down bracket by pulling on the tab indicated. / Entfernen Sie die Halterung, indem Sie an der gezeigten Lasche ziehen. / Retirez le cadre de maintien en appuyant sur la languette indiquée. / Rimuovere il supporto di abbassamento tirando sulla linguetta indicata.</p> 		
<p>10.</p> 		

Cleaning the Filter of the Fill Valve / Reinigung des Füllventilfilters /
Nettoyage du filtre de la vanne de remplissage / Pulizia del filtro della valvola di riempimento

11. As shown in the figure on the right, remove the filter*1 and aerator*2 from the fill valve. After removing the filter and aerator, either clean them with water or use a brush to clean any dirt from them. /
Entfernen Sie den Filter*1 und den Strahlregler*2 vom Füllventil, wie in der Abbildung rechts gezeigt. Nach dem Entfernen des Filters und des Strahlreglers reinigen Sie sie entweder mit Wasser, oder verwenden Sie eine Bürste, um möglichen Schmutz zu entfernen. /
Comme illustré sur la figure de droite, retirez le filtre*1 et l'aérateur*2 de la vanne de remplissage. Après avoir retiré le filtre et l'aérateur, nettoyez-les avec de l'eau ou utilisez une brosse pour nettoyer la saleté présente. /
Come illustrato nella figura a destra, rimuovere il filtro*1 e l'aeratore*2 dalla valvola di riempimento. Una volta rimossi il filtro e l'aeratore, pulirli con acqua o utilizzare una spazzola per eliminare lo sporco.

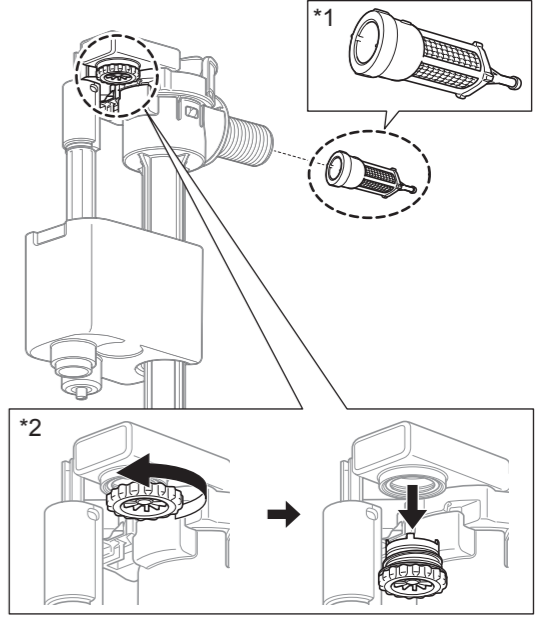

12. To install, follow the procedure in reverse to return the fill valve to its original position. /
Um das Füllventil wieder in seiner ursprünglichen Position einzubauen, gehen Sie in umgekehrter Reihenfolge vor. /
Pour l'installer, suivez la procédure dans le sens inverse pour remettre la vanne de remplissage dans sa position initiale. /
Per l'installazione, seguire la procedura inversa per riportare la valvola di riempimento alla sua posizione originale.